



**CARBON**  
TECHNOLOGIES

Aurora S-01 System

Automatic Chemiluminescence  
Immunoassay Analyzer

Operations Manual  
**AURORA S-01**





Automatic Chemiluminescence Immunoassay Analyzer Aurora S-01 System

## Table of Contents

### Chapter One: HOW TO USE THE MANUAL

### Chapter Two: MAJOR ICONS USED IN THE INSTRUMENT

- II1. Analyzer category
- II2. Warning labels
- II3. Indicative labels
- II4. Package labels

### Chapter Three: WARNING AND SAFETY INSTRUCTION

## **Chapter One: HOW TO USE THE MANUAL**

Thank you for using Aurora S-01 System Automatic Chemiluminescence Immunoassay Analyzer. Before operating the instrument, be sure to read the manual carefully. To get the best results, you must be aware of our instrument and its performance before clinical diagnosis and testing.

This is the operations manual for Aurora S-01 System Automatic Chemiluminescence Immunoassay Analyzer. It describes the installation, daily use and maintenance, etc. of the instrument. After reading the manual, please keep it properly for future reference.

### **Life Time**

The instrument is designed in having a life time of 5 years. If you want to use it for a longer period, you need to contact Carbon Technologies LLC to perform a calibration (to calibrate it as the instrument has been used for 5 years). If the safety and effectiveness can be confirmed, you can continue to use the instrument normally, if not, Carbon Technologies LLC should adjust the instrument till it meets the requirements.

The instrument is expected to be infective prior to the end of time, so the instrument is excluded from the scope of WEEE.

### **Meaning of Symbols**

#### **Warning**

Indicates when the user ignores this symbol and misuses the instrument, injury, serious injury or severe property loss may be caused to the user.

#### **Caution**

Indicates when the user ignores this symbol and misuses the instrument, personal injury, wrong results or property loss may be caused to the user.

#### **CAUTION:**

- The product is a clinical examination instrument for verification. Clinical diagnosis based on testing results should be conducted by doctors according to the clinical symptoms of the patients by combining other examination results.
- Wherever the operator or the user meet with places marked with  $\triangle$  on the analyzer, the manual shall be consulted to figure out potential dangers and measures to deal with them.
- Users shall attach great importance to information the manual provided and the analyzer shall be operated by personnel professionally trained by the manufacturer only.
- Users must read the manual carefully, especially the parts related to operation, precautions and safety of the analyzer to prevent possible loss and damage. Proper usage of the analyzer can insure accurate test results.

#### **WARNING:**

- To ensure the safety of the operator, the effective disposal of biohazard sources, and the proper maintenance of the analyzer, all personnel who might operate, repair, maintain the analyzer shall be trained before using the analyzer. Protective measures shall be taken while using the analyzer.
- Violation of the manual specified by the manufacturer may lead to damages of protective measures provided by the analyzer.
- Personnel shall be trained before conduct hazardous operations.

### Proprietary Statement

Carbon Technologies LLC reserves the right for the final explanation of the operations manual. The illustrations in the manual give typical examples only and may not be completely consistent with the actual displaying on the product. Take practicality as standard. Never use the illustrations for other purposes. Without written consent of Carbon Technologies LLC, no individual or organization may duplicate, modify or translate the contents of the manual. Carbon Technologies LLC will be responsible for the safety, reliability and performance of the product only when all the following requirements are met:

- Assembly, commissioning, expansion, improvement and repair should be conducted by persons recognized by Carbon Technologies LLC.
- The product is operated according to the manual.
- The related electrical equipment complies with the national standards.

### CAUTION:

The instrument must be used by medical examination professionals or trained doctors, nurses or laboratory technicians.

### WARNING:

- If no satisfied maintenance/repair plan is achieved, the instrument may fail abnormally and may endanger personal health.
- Ensure to use the instrument in the conditions specified in the manual. Otherwise, it may cause the instrument's failure to function normally and unreliable measurement results, damage the components of the instrument, and endanger personal safety.

## Chapter Two: MAJOR ICONS USED IN THE INSTRUMENT

### II1. Analyzer category

- IEC power supply protection class: Class I
- Overvoltage category: Category II
- Pollution degree: 2

### II2. Warning labels



Protective Earth (Ground)



Alternating Current / AC

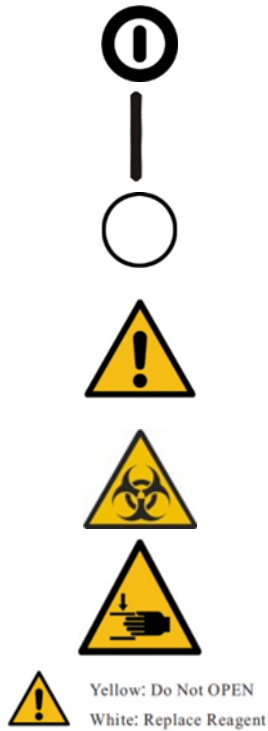

On/Off (Power)

On (Power)

Off (Power)

Caution:

- Be careful of the probe.
- Operator shall not touch or open the internal parts.
- Refer to the manual.

Warning:

- Potential biohazards.

Warning:

- Risk of pinching, indicating while in motion, cover part may pinch hands and cause injuries

Yellow: Do not open the reagent compartment.

White: Reagent compartment is operable.

### II3. Indicative labels



Serial number



Wash buffer tubing connector.

Attached to the silicone tubing connector on the left side of the analyzer.



Cleaning solution tubing connector.

Attached to the silicone tubing connector on the left side of the analyzer.



Liquid waste tubing connector.

Attached to the silicone tubing connector on the left side of the analyzer.



USB port.

Attached to the port on the back of the analyzer.



LAN port.

Attached to the port on the back of the analyzer.



Serial port.

Attached to the port on the back of the analyzer.

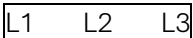

Liquid level detection interface, which are the detector interface of liquid waste, wash buffer, and cleaning solution from the left to the right. Attached on the left side of the analyzer.

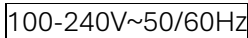

Power specifications and fuse specifications.



Attached to the back of the analyzer.



Meeting the requirement of the IVDR, and the instrument can be put into the European market.



Medical device for in vitro diagnosis.



Manufacturer.



Authorized representative in Europe.



Date of manufacture.



Consult instructions for use.

#### II4. Package labels



Temperature Limit.

The temperature limit of the transport package.



Fragile. Handle with care. The transport package contains fragile objects. Be careful during transportation.



This way up.

The correct position of the transport package is straight up.



Keep away from rain.

Protect the transport package against rain.



Prevent Sunshine. Avoid direct sunshine.



Do Not Roll.

Do not roll the transport package.

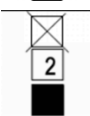

Stacking Limitation.

Stacking layers limited to 2 pieces.

### Chapter Three: WARNING AND SAFETY INSTRUCTION

Used only for in vitro diagnosis. Carefully read the following warning before using and strictly follow it.

#### Warning:

Read the following precautions carefully before using the instrument.

- In case of peculiar smell, smog or noise during use, immediately turn off the power and remove the plug from the socket, and immediately apply for inspection with the dealer or our agent. If you continue to use the instrument in that case, fire, electric shock or casualties may be caused.
- Prevent blood, reagent or metal pieces, such as staple, etc., from entering the instrument. Otherwise, short circuit or fire may be caused. In case of abnormality, immediately turn off the power and unplug the plug from the socket, and immediately apply for inspection with the dealer or our agent.
- Do not touch the electronic circuit in the instrument. Particularly, touch with wet hand may cause electric shock.
- Wear rubber gloves and use the specified tools, parts and components when maintaining and inspecting the instrument. When the operation is ended, wash hands with disinfectant. Otherwise, the skin exposed to blood may be infected or scalded or get an electric shock.
- Be very careful when treating samples. Be sure to wear rubber gloves. Otherwise, infection may be caused.
- In case the sample enters the eye or wound, immediately rinse with plenty of clean water and receive an examination by a doctor.
- Failure to use the instrument according to the methods specified for the instrument, the protection provided by the instrument may be destroyed.

**Standards and directives:**

- IEC 61326-1: 2020 Electrical equipment for measurement, control and laboratory use EMC requirements Part 1: General requirements.
- IEC 61326-2-6: 2020 Electrical equipment for measurement, control and laboratory use - EMC requirements Part 2-6: Particular requirements - In vitro diagnostic (IVD) medical equipment.
- IEC 61010-2-101: 2018 Safety requirements for electrical equipment for measurement, control and laboratory use - Part 2-101: Particular requirements for in vitro diagnostic (IVD) medical equipment.
- IEC 61010-1: 2010 Safety requirements for electrical equipment for measurement, control, and laboratory use -Part 1: General requirements. Standards and Directives.

**Use and disposal of reagent:**

- Prevent the reagent from being in contact with skin and clothing during operation.
- In case the reagent enters the eye, immediately rinse with plenty of clean water and receive an examination by a doctor.
- In case the hand or skin is exposed to the reagent, immediately wash with clean water.
- The cleanser supporting the instrument is strong alkali cleanser. Do not allow the skin or clothing to be exposed to it. In case the skin or clothing is exposed to it, immediately rinse with plenty of water to prevent injury.
- Used test tubes and other consumables for the instrument should be disposed properly as medical waste or infectious waste. If contaminated by blood, etc., they may be infected by pathogen.

**Voltage, connection and grounding of power supply:**

- Ensure that the power supply and grounding environment of the instrument are good and stable.
- Never insert the power plug into a socket out of the allowed voltage range. Otherwise, fire or electric shock may be caused.
- Be sure to use the power cable supplied with the instrument in installation, ensure good grounding, and put the instrument in a place for easy power off operation. Otherwise, fire or electric shock may be caused.
- Never damage the insulating covering of the cable. Do not jerk the cable or hang heavy objects with the cable. Otherwise, short circuit or open circuit may be caused, thus causes electric shock or fire.
- Be sure to turn off the power before connecting peripheral equipment. Otherwise, electric shock or failure may be caused.
- Modification of medical instruments is prohibited.

**Biohazard****CAUTION**

- Do not eat, drink, or smoke in the laboratory.
- When operating the analyzer, the operator should wear a lab coat and medical protective gloves.
- Handling potentially infectious samples. When handling potentially infectious samples, the operator must wear the following:

- Lab coat
- Disposable gloves
- Protective eyewear
- Medical masks
- Avoid splashing or spilling infectious fluids on any exposed part of the body. Immediately clean an affected area with water if any exposure to biohazardous or potentially infectious materials occurs. Follow the facility disinfection and sterilization guidelines.
- Handling potentially contaminated system components. Take extra care and wear protective equipment when handling the following components. These components are considered potentially infectious because they have been in contact with samples and reagents.
  - Pipettor
  - Pipettor wash cup
  - Liquid waste nozzle
  - Liquid waste tubing
  - RV waste container
- Disinfection and sterilization  
The tools and instruments used in the examination or repairing must be disinfected with 75% medical alcohol before being put back in place. Before repairing the analyzer, the field service engineer should ensure that parts of the analyzer that may contain biohazards are properly disinfected (Wipe the surface of the parts with 75% medical alcohol), and wear protective equipment when necessary.

## **WARNING**

- Disposal of all waste must be in accordance with local, state, and national regulations.
- In accordance with the Pharmaceutical Affairs Law, modification of medical instruments is prohibited.



# Table of Contents

## Chapter 1 - OVERVIEW

<b>1.1 Primary components</b> .....	<b>20</b>
1.1.1 Sample/Reagent system .....	21
1.1.2 RV arrangement module .....	21
1.1.3 RV gripping module .....	22
1.1.4 Dispense system .....	22
1.1.5 Incubation/Detection system .....	23
1.1.6 Wash system .....	23
1.1.7 Fluidic system .....	24
1.1.8 Frame/Cover system .....	24
1.1.9 Electronic control system .....	25
1.1.10 Aurora software (Aurora S-01 System) .....	25
-Software user interface layout .....	25
-Product information button .....	26
-Menu area .....	26
-Analyzer control area .....	29
-Power button .....	30
-Shortcut and component status buttons .....	30
-Notification center .....	30
1.2 Intended use .....	31
1.3 Equipment life and contraindications .....	31
1.4 Principles of operation .....	31
1.4.1 Chemiluminescence principle (Aurora S-01 System) .....	31
1.4.2 Immune reaction methods .....	31
-Sandwich immunoassays (Aurora S-01 System) .....	31
-Competitive immunoassays (Aurora S-01 System) .....	32
1.4.3 Magnetic separation technique .....	32
1.5 Manufacturer Information .....	33
1.5.1 Manufacturer .....	33
1.5.2 Address .....	33
1.5.3 Phone .....	33
1.5.4 Email .....	33
1.6 Technical support center .....	33
1.6.1 Company .....	33
1.6.2 Registered address .....	33

1.6.3 Phone	33
1.6.4 Email	33
1.7 European representative	33
1.7.1 EU representative	33
1.7.2 Address	33

## Chapter 2 - SPECIFICATIONS

<b>2.1 Software operating specifications</b>	<b>33</b>
2.1.1 Computer requirements	33
2.1.2 Operating system	33
2.1.3 Network	34
2.2 Network security	34
2.2.1 Security software	34
2.2.2 Data ports	34
2.2.3 Limitation of access	34
2.2.4 User access mechanism	34
-User identification method	34
-User groups	34
-Limits of authority	34
2.2.5 Software updates	34
2.2.6 External devices	34
2.3 Environmental specifications and requirements	35
2.4 Performance requirements	35
2.4.1 Appearance	35
2.4.2 Correctness and repeatability of dispensing volumes	35
2.4.3 Correctness and fluctuation of temperature control in the reaction area	35
2.4.4 Optical specifications	35
2.4.5 Carryover contamination rate	36
2.4.6 Within-run precision for clinical assays	36
2.5 Functionality	36
2.5.1 Barcode types supported by the built-in barcode reader	36
-Linear barcodes	36
-2D barcodes	37
2.6 Software features	37
2.7 Product model	37

## Chapter 3 - INSTALLATION

<b>3.1 Installation tips</b>	<b>37</b>
------------------------------	-----------

3.2 Installation requirements ... ..	37
3.3 Installation process ... ..	38
3.3.1 Analyzer unboxing and installation ... ..	38
3.3.2 Connections ... ..	40

## Chapter 4 - ANALYZER CONFIGURATION

<b>4.1 Assay configuration ... ..</b>	<b>43</b>
4.1.1 Assays ... ..	43
-Add assays to and remove assays from the current assays ... ..	43
-Configure control rules ... ..	44
-Configure retest rules ... ..	46
4.1.2 Assay Panel ... ..	47
-Add assay panel ... ..	48
-Modify assay panel ... ..	48
-Delete assay panel ... ..	48
4.1.3 Calculated assays ... ..	49
-View calculated assays ... ..	49
-Add calculated assay ... ..	49
4.2 System configuration ... ..	49
4.2.1 General settings ... ..	50
-System date and time ... ..	50
-Tests refresh time ... ..	50
-Info volume ... ..	50
-Alert volume ... ..	50
-Critical volume ... ..	50
-Daily maintenance reminder ... ..	50
-System language ... ..	51
-Range specifier ... ..	51
-Range delimiter ... ..	51
-Assay columns per row ... ..	51
-Assay panel columns per row ... ..	51
-Reagent columns per row ... ..	51
-Assays displayed in orders screens ... ..	51
4.2.2 Consumables settings ... ..	51
-Quality control interval ... ..	51
-Usable while calibration not OK ... ..	51
-Reagent low notification ... ..	51
-Reagent open-bottle stability ... ..	52
-Default time range for display of historical reagents ... ..	52

-Substrate open-bottle stability ... ..	52
-Diluent open-bottle stability ... ..	52
-Enhanced cleaning solution open-bottle stability ... ..	52
-Substrate remaining notification ... ..	52
-Diluent remaining notification ... ..	52
-Enhanced cleaning solution remaining notification ... ..	52
-RV remaining notification ... ..	52
-RV waste notification ... ..	53
4.2.3 Specimens' settings ... ..	53
-Default specimen type ... ..	53
-Default specimen container ... ..	53
-Automatic sequence number ... ..	53
-Auto sequence number format ... ..	53
-Allow duplicate sample ID ... ..	53
-Default primary keyword for sample order selection ... ..	53
-Result value below the lower normal reference range ... ..	53
-Result value above the upper normal reference range ... ..	53
-Result value below the lower critical reference range ... ..	53
-Result value above the upper critical reference range ... ..	53
4.2.4 Controls settings ... ..	54
-Replicates of test per concentration level ... ..	54
-Default time range for display ... ..	54
-Controls and associated assays ... ..	54
-Add a control and its associated assay ... ..	54
-Modify a control and its associated assay ... ..	54
-Delete a control and its associated assay ... ..	54
4.2.5 Calibrators settings ... ..	55
-Replicates of test per concentration level ... ..	55
-Default time range for display ... ..	55
-Calibrators and associated assays ... ..	55
-Add a calibrator and its associated assay ... ..	55
-Modify a calibrator and its associated assay ... ..	55
-Delete a calibrator and its associated assay ... ..	56
4.2.6 LIS settings ... ..	56
-Basic LIS parameters ... ..	56
-TCP/IP network connection parameters ... ..	57
-Serial port connection parameters ... ..	58
-Assay test code ... ..	58
4.2.7 User settings ... ..	58
-View all authorized users ... ..	58

- Add a user ... ..59
- Change user password ... .. 59
- Change user group ... ..59
- Delete a user ... .. 59
- 4.2.8 Print settings ... ..60
  - Printer name ... .. 60
  - Printing mode ... ..60
  - Name ... ..60
  - Address ... .. 60
  - Mailbox ... .. 60
  - Phone ... ..60
  - Assay print order ... ..60
- 4.3 Table configuration ... .. 60
- 4.4 Dictionary configuration ... ..61
  - 4.4.1 Add data ... ..61
  - 4.4.2 Modify data ... .. 62
  - 4.4.3 Delete data ... ..62

**Chapter 5 - OPERATING INSTRUCTIONS**

- 5.1 Daily operation procedure ... ..62**
- 5.2 Analyzer power, user login, and analyzer initialization ... .. 62
  - 5.2.1 Cycle power to the analyzer ... .. 63
  - 5.2.2 User login ... .. 63
    - First login after boots up ... ..64
    - Switch current user ... ..64
  - 5.2.3 Analyzer initialization ... .. 64
- 5.3 Preparation before performing sample processing ... ..64
  - 5.3.1 Check supply status ... .. 64
  - 5.3.2 Check reagent status ... ..64
  - 5.3.3 Check the analyzer maintenance status ... ..64
  - 5.3.4 Check LIS connection status ... .. 65
  - 5.3.5 Check printer status ... ..65
- 5.4 Order creation ... .. 65
- 5.5 Analyzer control ... ..65
  - 5.5.1 Start ... .. 65
  - 5.5.2 Pause ... ..65
  - 5.5.3 Stop ... ..65
- 5.6 Analyzer status monitoring ... .. 66
  - 5.6.1 Reagent status ... .. 66

5.6.2 Sample status .....	66
5.6.3 Supply status .....	67
5.6.4 Test data status .....	67
5.7 Results handling .....	67
5.8 Analyzer shutdown and restart .....	67

## Chapter 6 - REAGENT AND SUPPLY MANAGEMENT

<b>6.1 Reagent inventory management .....</b>	<b>68</b>
6.1.1 Check reagent status .....	68
6.1.2 Load reagents .....	68
-Automatic reagent loading .....	68
-Manual reagent loading .....	69
6.1.3 Unload reagents .....	69
-Automatic reagent unloading .....	70
-Manual reagent unloading .....	70
6.1.4 Disable reagents .....	70
-Disable reagents .....	70
-Re-enable reagents .....	71
6.1.5 Set reagents as current bottles .....	71
6.1.6 Extend validity of calibration parameters .....	71
-Enable calibration extension .....	72
-Disable calibration extension .....	72
6.1.7 Select calibration curve .....	72
6.1.8 Historical reagents .....	72
6.1.9 Print reagent list .....	73
6.2 Supply inventory management .....	73
6.2.1 Check supply status .....	74
-Load substrates .....	74
-Read substrate information with a barcode reader .....	74
-Enter substrate information manually .....	74
6.2.2 Load diluent on the sample carousel .....	75
-Automatic diluent loading .....	75
-Manual diluent loading .....	75
6.2.3 Load enhanced cleaning solution to sample carousel .....	76
-Automatic enhanced cleaning solution loading .....	76
-Manual enhanced cleaning solution loading .....	77
6.2.4 Replenish cleaning solution .....	77
6.2.5 Replenish wash buffer .....	77
6.2.6 Load RVs .....	77

6.2.7 Empty the RVs waste container .....	78
6.2.8 Replace the liquid waste container .....	78

## Chapter 7 - CALIBRATION PROCEDURES

<b>7.1 Input calibrator information .....</b>	<b>79</b>
7.1.1 Add bar-coded calibrator information .....	79
-Scan the barcode with a barcode reader .....	79
-Input the barcode in the software user interface .....	79
7.1.2 Add calibrator information manually .....	79
7.1.3 View calibrator information .....	80
7.1.4 Modify calibrator information .....	81
7.1.5 Delete calibrator information .....	81
7.2 Create calibration orders .....	81
7.3 Shortcut to create calibration orders for onboard reagents .....	82
7.4 Input master curve information .....	83
7.4.1 Manual master curve information card scanning .....	83
7.5 View master curve information .....	83
7.6 View and apply the calibration curve .....	84
7.6.1 View the calibration curve .....	84
7.6.2 Switch and apply the calibration curve .....	84
7.7 View and apply calibration cutoff information .....	85
7.7.1 View the calibration cutoff information .....	85
7.7.2 Switch and apply the calibration cutoff information .....	85

## Chapter 8 - QUALITY CONTROL PROCEDURES

<b>8.1 Control rule configuration .....</b>	<b>86</b>
8.2 Input control information .....	86
8.2.1 Add bar-coded control information .....	86
-Scan the barcode with a barcode reader .....	86
-Input the barcode in the software user interface .....	86
8.2.2 Add control information manually .....	86
8.2.3 View control information .....	87
8.2.4 Modify control information .....	88
8.2.5 Delete control information .....	88
8.2.6 Add control combination .....	89
8.3 Create control orders .....	89

8.3.1 Create an individual control order ... ..	89
-Create orders for a control combination ... ..	90
8.4 Shortcut to create control orders for onboard reagents ... ..	91
8.5 View the Levey-Jennings chart ... ..	91
8.5.1 Display the Levey-Jennings chart for an assay ... ..	91
8.5.2 View the Levey-Jennings point details ... ..	92

## Chapter 9 - SPECIMEN ORDER PROCEDURES

<b>9.1 Create specimen orders ... ..</b>	<b>92</b>
9.1.1 Manually create specimen test orders ... ..	92
-Order an individual specimen test ... ..	93
-Batch specimen test ordering ... ..	94
9.1.2 Inquire specimen test orders via network ... ..	95
-Automatic inquiry ... ..	95
-Manual inquiry ... ..	96
9.2 Patient information ... ..	96
9.2.1 View and edit patient information ... ..	96

## Chapter 10 - SAMPLE MANAGEMENT

<b>10.1 Addition, deletion and modification of sample tests ... ..</b>	<b>97</b>
10.1.1 Individual editing of a sample order ... ..	97
10.1.2 Batch editing of sample orders ... ..	97
10.2 Sample loading and unloading ... ..	98
10.2.1 Automatic loading and unloading ... ..	98
10.2.2 Manual loading and unloading ... ..	98
-Manual loading sample ... ..	98
-Manual unloading sample ... ..	99
10.3 Deletion of sample ... ..	99
10.4 Sample order selection ... ..	100
10.4.1 Select a sample order ... ..	100

## Chapter 11 - DATA HANDLING

<b>11.1 View data ... ..</b>	<b>101</b>
11.1.1 View test information ... ..	101
-View all tests ... ..	101
-View tests by sample ... ..	102
-View tests by assay ... ..	102



11.1.2 View statistics .....	103
-View the total number of specimen tests .....	103
-View the total number of assay tests .....	104
-View result statistics of assay tests .....	104
11.1.3 View test exceptions .....	105
11.2 Create rerun orders .....	106
11.2.1 Automated retest .....	106
11.2.2 Manual retest .....	106
11.2.3 View and select retest results .....	106
11.3 Recalculate results .....	107
11.4 Cancel orders .....	107
11.5 Release results .....	108
11.6 Transmit results .....	108
11.6.1 Automatic transmission .....	108
11.6.2 Manual transmission .....	108
11.7 Print results .....	108
11.7.1 Print the specimen report .....	108
11.7.2 Print the raw data .....	109
11.8 Export raw data .....	110
11.8.1 Export raw data .....	111
11.9 Result flags .....	111

## Chapter 12 - CARE AND MAINTENANCE

<b>12.1 Routine maintenance .....</b>	<b>114</b>
12.2 Preventive maintenance and inspection instructions .....	114
12.3 Hardware status .....	114
12.3.1 Temperature .....	114
12.4 Maintenance Operation .....	115
12.4.1 View maintenance procedures .....	115
12.4.2 Maintenance commands .....	115
-Integrated maintenance commands .....	115
-Unit maintenance commands .....	116
12.4.3 Maintenance types and means .....	116
-Automatic maintenance procedures .....	116
-Manual maintenance procedures .....	116
12.5 Logs .....	116
12.5.1 Log Type .....	116
-Notification logs .....	117
-Edit logs .....	117

-Operation logs .....	117
-Maintenance logs .....	117
12.5.2 Log operations .....	117
-Search .....	117
-Export .....	117
-Print .....	118
12.6 Maintenance procedures by frequency .....	118
12.6.1 Daily .....	118
12.6.2 Weekly .....	118
12.6.3 Monthly .....	118
12.6.4 Quarterly .....	119
12.6.5 Semiyearly .....	119
12.6.6 Yearly .....	119

## Chapter 13 - COMMON ISSUES AND SOLUTIONS

<b>13.1 Forms of notification .....</b>	<b>120</b>
13.1.1 Color change .....	120
13.1.2 Speaker sound .....	120
13.1.3 Pop-up window .....	120
13.1.4 Notification center .....	120
13.1.5 Notification messages list .....	120
-View current notification messages .....	120
-View historical notification messages .....	121
13.1.6 User interface border with breathing effect .....	121
13.2 Handling notifications .....	121
13.2.1 Mark as read .....	121
-Mark as read in the notification center .....	121
-Mark as read on the notification screen under the maintain menu .....	121
13.2.2 Display help information .....	122
13.2.3 Clear the notification message .....	122
-Clear the message automatically .....	122
-Clear the message manually .....	122
-Handle command failures .....	122
13.3 Messages .....	123
13.3.1 Category codes for analyzer messages reported by the computer .....	123
13.3.2 Analyzer messages reported by the computer .....	123
13.3.3 Parts codes for command failure messages reported by the controller .....	134
13.3.4 Command failures reported by the controller .....	135

**Chapter 14 - PRECAUTIONS AND REQUIREMENTS**

- 14.1 Precautions during installation ... .. 140**
- 14.2 Precautions with operation ... .. 140
- 14.3 Safety precautions ... ..141
- 14.4 Other precautions ... ..141

**Chapter 15 - TRANSPORTATION AND STORAGE**

- 15.1 Transportation ... ..142**
- 15.2 Storage ... ..143

**Chapter 16 - AFTER-SALES SERVICES**

- 16.1 Warranty period ... ..143**
- 16.2 Maintenance and replacement of consumable parts ... .. 143
  - 16.2.1 Replacement of fuse ... .. 143
  - 16.2.2 Replacement of tubing ... .. 144
- 16.3 Calibration of the analyzer ... ..144
  - 16.3.1 Mechanical performance ... ..144
    - Requirements ... .. 144
    - Method ... ..144
  - 16.3.2 Incubation temperature ... ..144
    - Requirements ... .. 144
    - Method ... ..144
  - 16.3.3 Calibration of dispense volume and wash residual volume ... ..144
    - Requirements ... ..144
    - Method ... ..145
  - 16.3.4 Photomultiplier tube performance ... .. 145
    - Requirements ... ..145
    - Method ... ..145
  - 16.3.5 Correlation coefficient ... ..145
    - Requirements ... .. 145

**Chapter 17 - ELECTROMAGNETIC COMPATIBILITY**

- 17.1 Electromagnetic emission and immunity ... ..145**
  - 17.1.1 Radio frequency radiation ... .. 146
  - 17.1.2 Radiation immunity ... ..146
- 17.2 Installation environment ... ..146

17.3 External devices .....147

## Chapter 1 - Overview

### 1.1 Primary components

The analyzer consists of a sample/reagent system, a dispense system, a RV arrangement module, a RV gripping module, an incubation/detection system, a wash system, a frame/cover system, a fluidic system, an electronic control system (including controller) and the operating software. Among them, the operating software is the system control software.

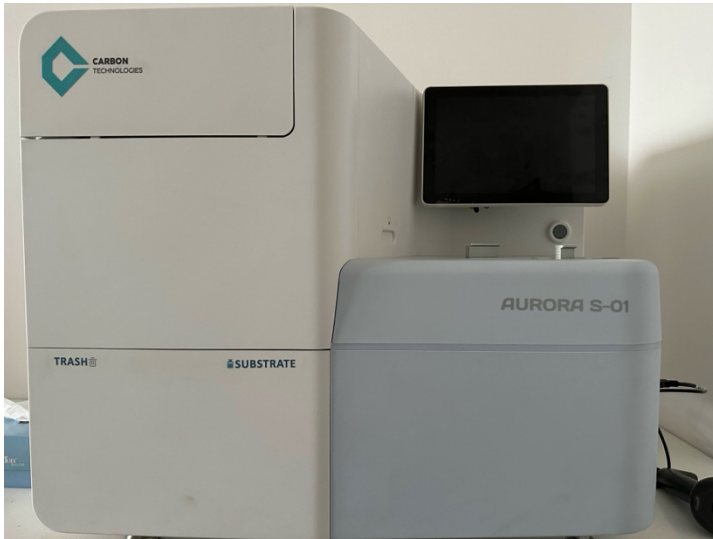

Figure: Front of the analyzer



Figure: Left of the analyzer

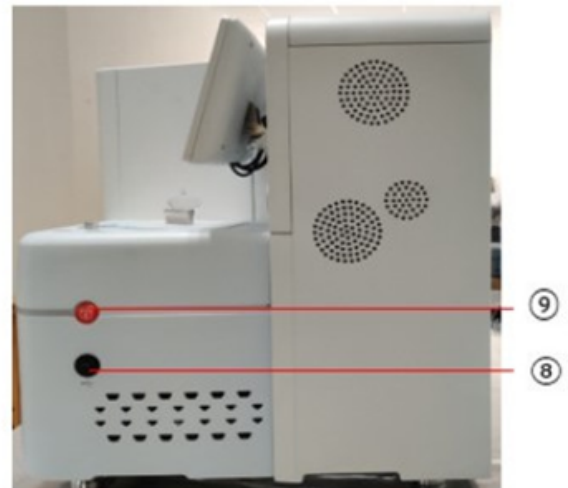

Figure: Right of the analyzer

#### Legend:

- ① RV hopper cover
- ② Waste/substrate compartment door
- ③ Monitor
- ④ Computer power switch
- ⑤ Reagent/sample compartment

- Ⓞ System power switch
- Ⓞ Tubing connectors and liquid sensor connection ports:
  - The upper row: Wash buffer liquid sensor (L1)
  - Cleaning solution liquid sensor (L2)
  - Liquid waste liquid sensor (L3)
  - The middle row: Wash buffer tubing connector (P1)
  - Wash buffer tubing connector (P1)
  - Cleaning solution tubing connector (P2)
  - The lower row: Liquid waste tubing connector (P3)
- Ⓞ USB port
- Ⓞ Emergency stop button

### 1.1.1 Sample/Reagent system

The sample/reagent system is located inside the analyzer at the front-right position and consists of a reagent carousel component, a sample carousel component, and a barcode reader. The reagent carousel component is a circular structure, and the sample carousel component is an annular structure. The reagent carousel and sample carousel are coaxially nested. The sample carousel component is located on the outer ring of the reagent carousel. The barcode reader is located on the side of the sample carousel component, as shown in the Figure: Sample/Reagent system. The primary function of this system is to pipette samples and reagents required for the assay tests. Samples and reagents must correspond to the specified assay tests. The sample/reagent system has the ability to identify the sample/reagent by reading the barcodes, to provide a specific low-temperature environment for the reagents, and to perform real-time mixing of the magnetic microparticles. This system is also the system to place sample racks. By reading the barcode on the sample containers, the system can identify and request test information for each sample.

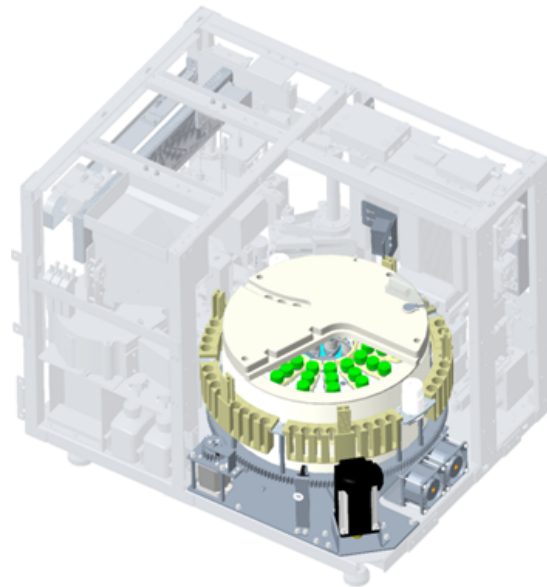

Figure: Sample/Reagent system

### 1.1.2 RV arrangement module

The RV arrangement module is located inside the front of the analyzer at the top-left position and mainly consists of the RV compartment, automatic RV arrangement structure, dispense carousel, and mixing module, as shown in the Figure: RV arrangement module. The main function of this module is to arrange the disorganized RVs into an orderly state and to provide RVs for assay tests.

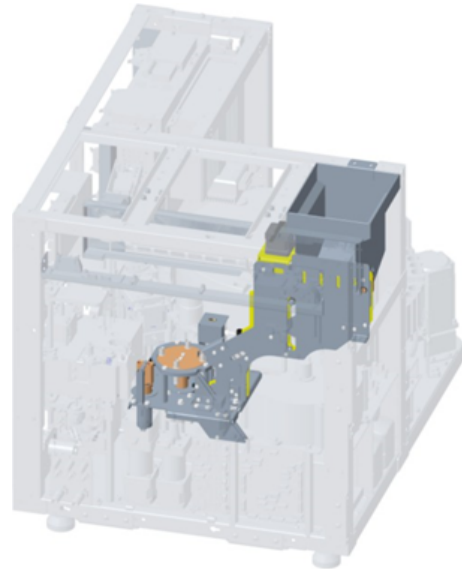

Figure: RV arrangement module

### 1.1.3 RV gripping module

The RV gripping module is located inside the analyzer at the top-left position and mainly consists of a crosspiece component, a gripping arm component, and a gripper component, as shown in Figure: RV gripping module. The main function of this module is to transport RVs through the dispense system, the wash system, and the incubation/detection system. It also provides the function of RV disposal.

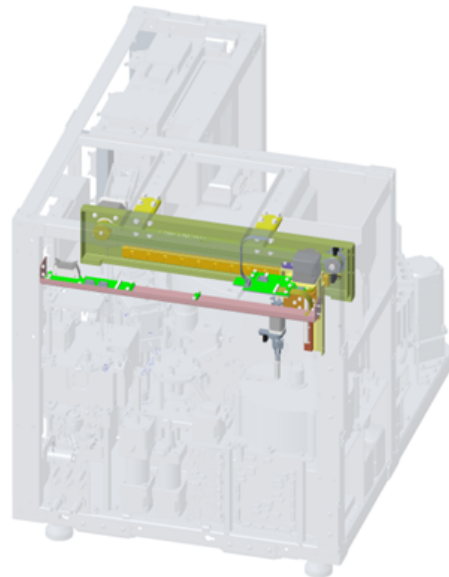

Figure: RV gripping module

### 1.1.4 Dispense system

The dispense system is located inside the analyzer at the rear end near the middle and mainly consists of a pipettor, a support arm, a mounting base, and a movement mechanism, as shown in Figure: Dispense system. The main function of this system is to dispense samples, reagents, and diluents into the reaction vessels on the dispense carousel. The pipettor can be washed with the cleaning solution or the enhanced cleaning solution.

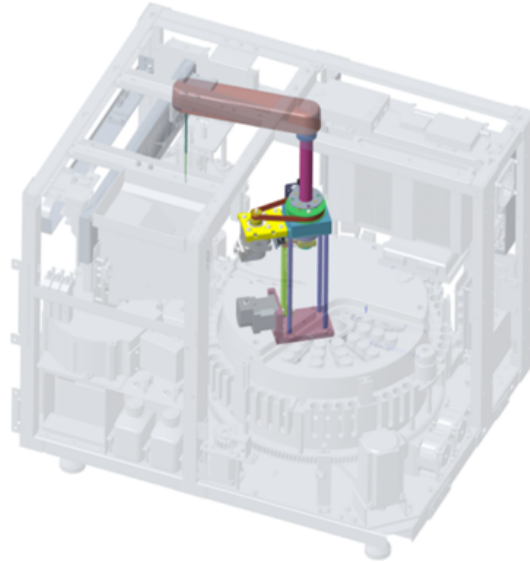

Figure: Dispense system

### 1.1.5 Incubation/Detection system

The incubation/detection system is located inside the analyzer at the front left position and mainly contains the photometer, the movement mechanism, a carousel, a heating module, and incubation frame, as shown in Figure: Incubation/Detection system. The main function of this system is to provide an incubation environment at a controlled constant temperature for the mixed reaction vessels, perform photometric analysis on the reaction vessels and return the test results.

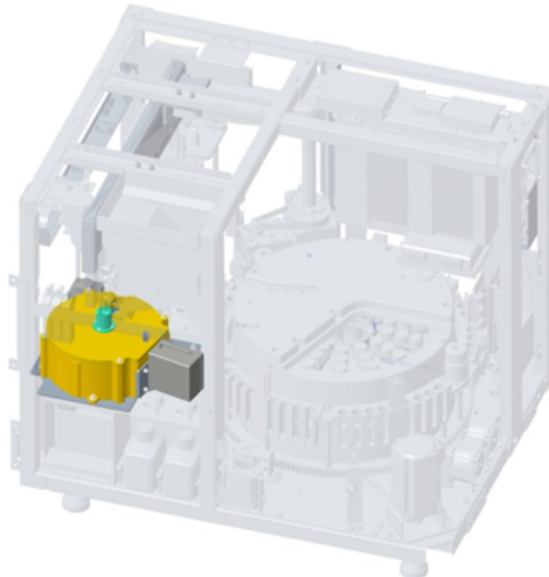

Figure: Incubation/Detection system

### 1.1.6 Wash system

The wash system is located inside the analyzer on the left side of the rear end and mainly contains the wash cover, the wash carousel, the movement mechanism, the wash station, the substrate dispense module, and the heating module, as shown in Figure: Wash system. The main function of this system is to process the RVs that have completed incubation by washing the reaction mixture and removing unbound materials from it, then adding the substrates required for the reaction.



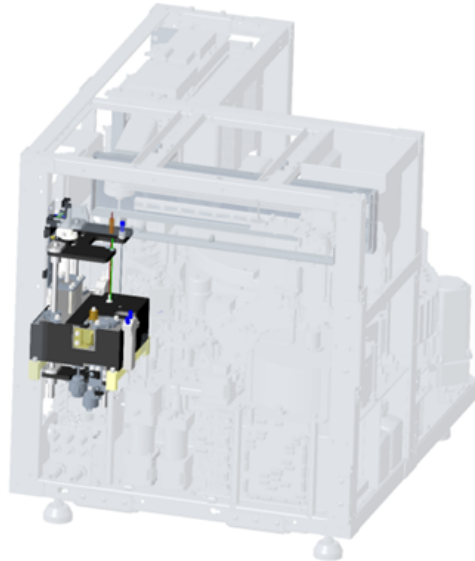

Figure: Wash system

### 1.1.7 Fluidic system

The fluidic system runs through the sample/reagent system, the dispense system, the pipettor wash module, the washing system, and the incubation/detection system, as shown in Figure: Location of pumps and valves in the fluidic system. The main function of this system is to manage the analyzer's fluidic circuits in an integrated manner, rationalize the layout of piping, streamline the use of pumps and valves, provide stable liquid dispensing and aspiration functions for other systems, and facilitate the control and maintenance of the fluidic circuit.

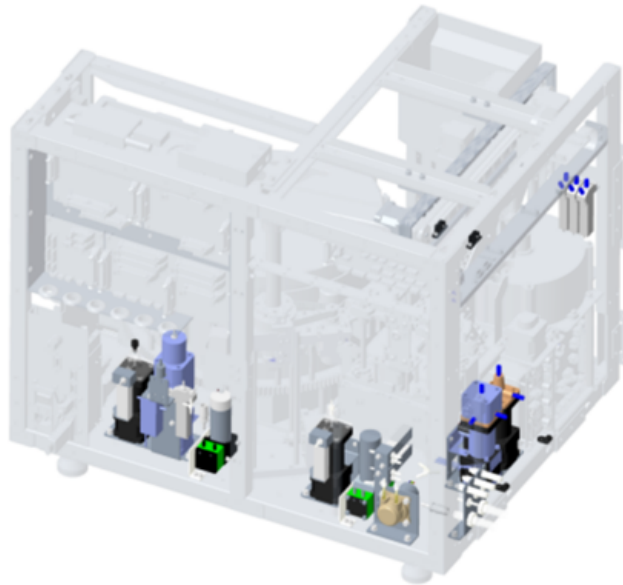

Figure: Location of pumps and valves in the fluidic system

### 1.1.8 Frame/Cover system

The frame system is the support structure for the instrument. The frame system provides fixed locations for each subsystem for installation and facilitates the associated parts to stay in the exact position relative to each other. With sufficient strength and rigidity, the frame system can ensure a good condition of the analyzer during

transportation, installation, and operation. The cover system is the exterior cover of the instrument and the safety protection for the systems.

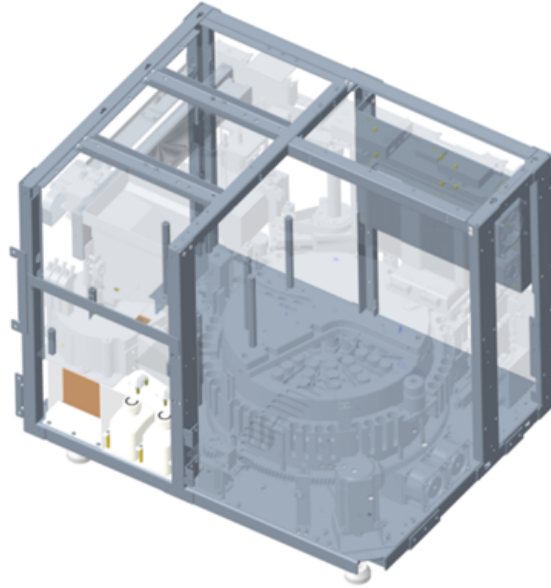

Figure: Frame System

#### 1.1.9 Electronic control system

The electronic control system mainly consists of a 24V/5V power switch, a socket filter, a tablet PC, and other components. The main function is to control the power connection of the analyzer and to provide 5V and 24V power for other systems of the analyzer.

#### 1.1.10 Aurora software (Aurora S-01 System)

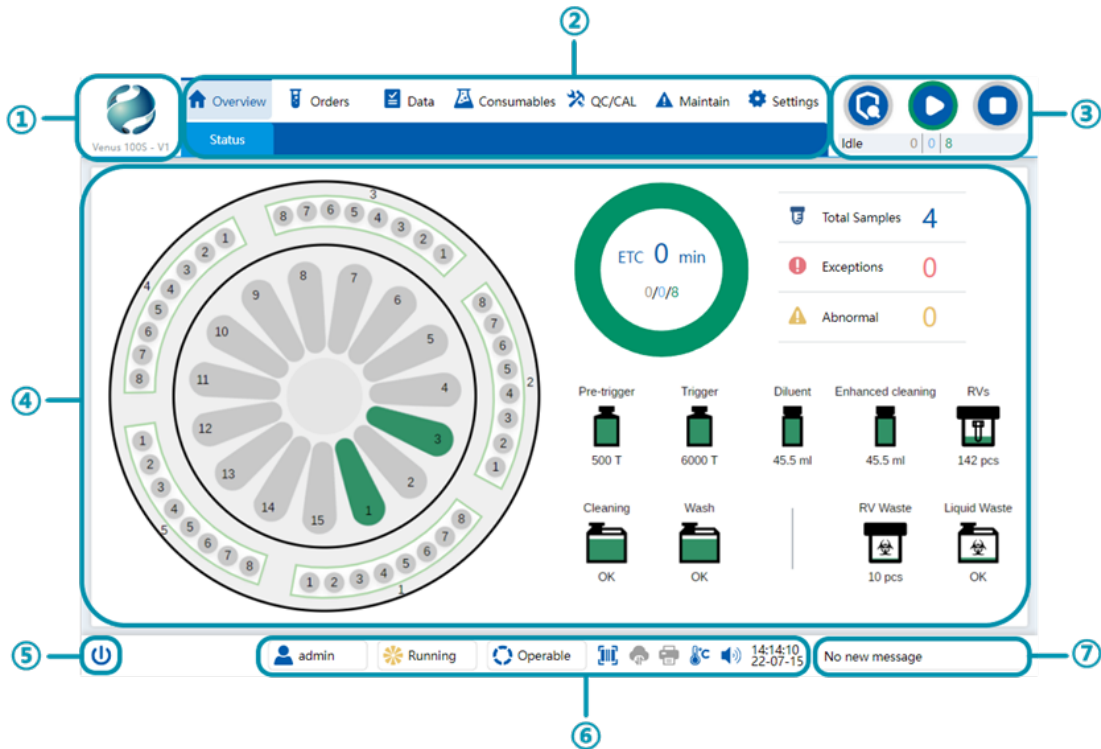

Figure: Software user interface layout

**Legend:**

- ① Product information button
- ② Menu area
- ③ Analyzer control area
- ④ Information area
- ⑤ Power button
- ⑥ Shortcut and component status buttons
- ⑦ Notification center

**Product information button**

Displays the manufacturer logo and the current software version. When this button is tapped, the product information window will be displayed. The product information window displays the product model, the software version, the complete software version, the software release date, the complete hardware version, the manufacturer information, and the copyright claim.

**Menu area**

Consists of a primary menu and a secondary menu for navigation to different screens. The primary menu items are represented by an icon with text, and the secondary menu items are represented by text only. The content of the secondary menu is dependent upon the selection of the primary menu item. The primary menu items include the following contents.

**Overview**

Displays the analyzer status overview, including the status of onboard samples, onboard reagents, supplies, the estimated time of completion for all tests in the system, the total samples tested for the day, the number of test exceptions for the day, and the number of tests with abnormal results for the day.

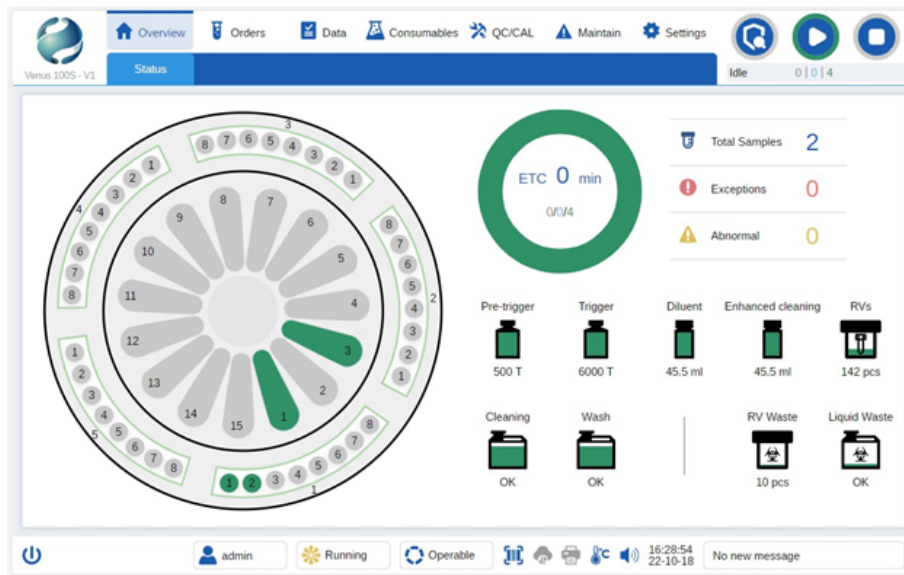

Figure: [Status] screen under the [Overview] primary menu item

## Orders

View and edit test orders for samples of different types. Users can view orders for specimen tests, quality control tests, and calibration tests. Users can also view orders loaded and orders unloaded.

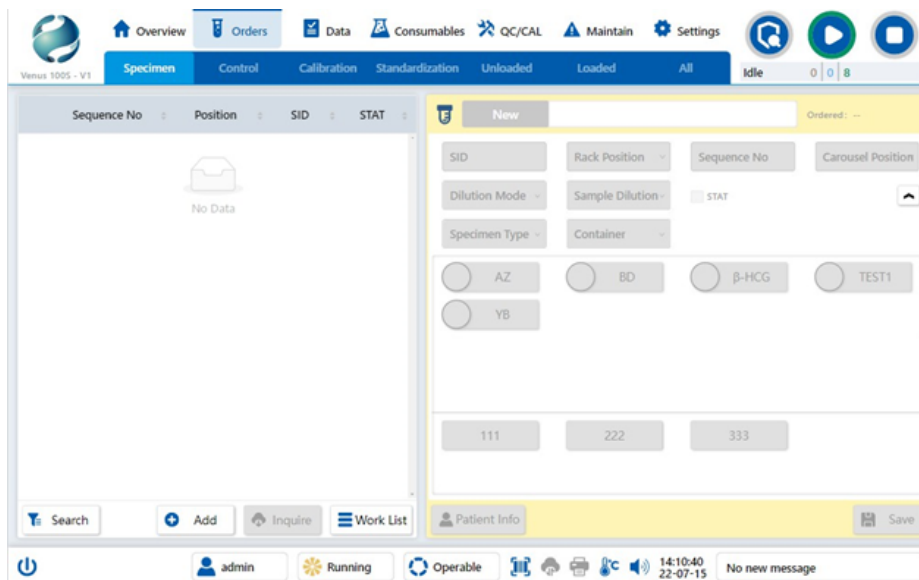

Figure: [Specimen] screen under the [Orders] primary menu item

## Data

Provides access to view and handle results for all tests, tests grouped by samples, tests grouped by assays, abnormal tests and test-oriented statistics with the associated secondary menu selected. The tests listed are of the current day by default. The user can search for historical tests by entering search conditions.

Sample Type	Sequence No	SID	Assay	Test Status	Result	RLU	Flags	Unit	Rerun
Control	--	--	AZ	✓ Completed	458.21	5000	--	mg/l	22-0
Control	--	--	AZ	✓ Completed	458.21	5000	--	mg/l	22-0
Control	--	--	AZ	✓ Completed	458.21	5000	--	mg/l	22-0
Control	--	--	AZ	✓ Completed	458.21	5000	--	mg/l	22-0
Control	--	--	BD	✓ Completed	4.92	5000	--	g/dl	22-0
Control	--	--	BD	✓ Completed	4.92	5000	--	g/dl	22-0
Control	--	--	BD	✓ Completed	4.92	5000	--	g/dl	22-0
Control	--	--	BD	✓ Completed	4.92	5000	--	g/dl	22-0

Figure: [Test] screen under the [Data] primary menu item

### Consumables

Provides access for reagent and supply management. Users can view all detailed information for all onboard reagents and supplies, order QC or calibration tests, load or unload reagents and supplies.

Position	Name	Lot	Remaining	Stability	EXP Date	Status	SN
1	BD* M	20220601	500T	30D	23-07-01	OK	11
2							
3	BD M	20220601	500T	84D	22-09-09	OK	2
4							
5							
6							
7							
8							
9							
10							

Figure: [Reagents] screen under the [Consumables] primary menu item

### QC/CAL

Provides access to view L-J charts and reagent curve information, and to edit information for controls and calibrators.

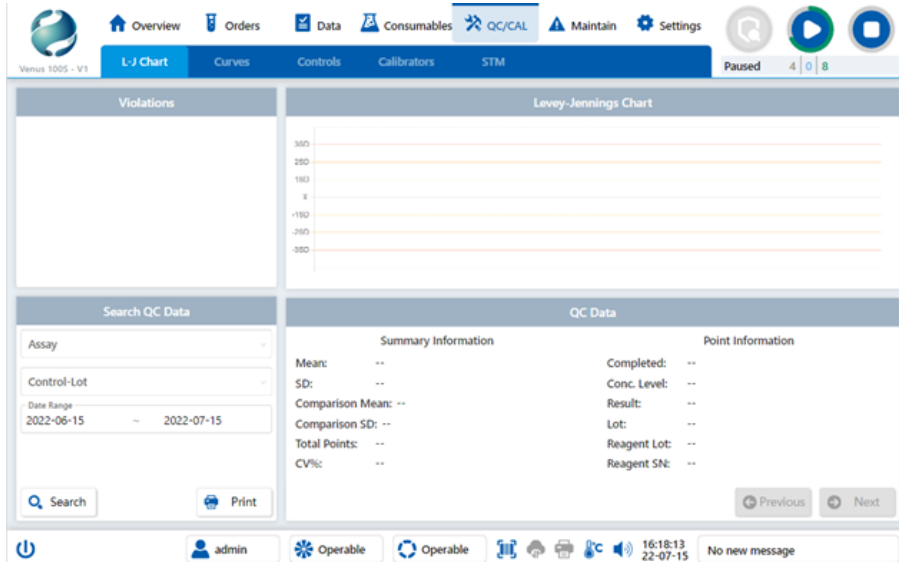

Figure: [L-J] chart screen under the [QC/CAL] primary menu item

## Maintain

Provides access to view and handle notification messages, perform system maintenance and diagnosis, and inspect the status of analyzer components.

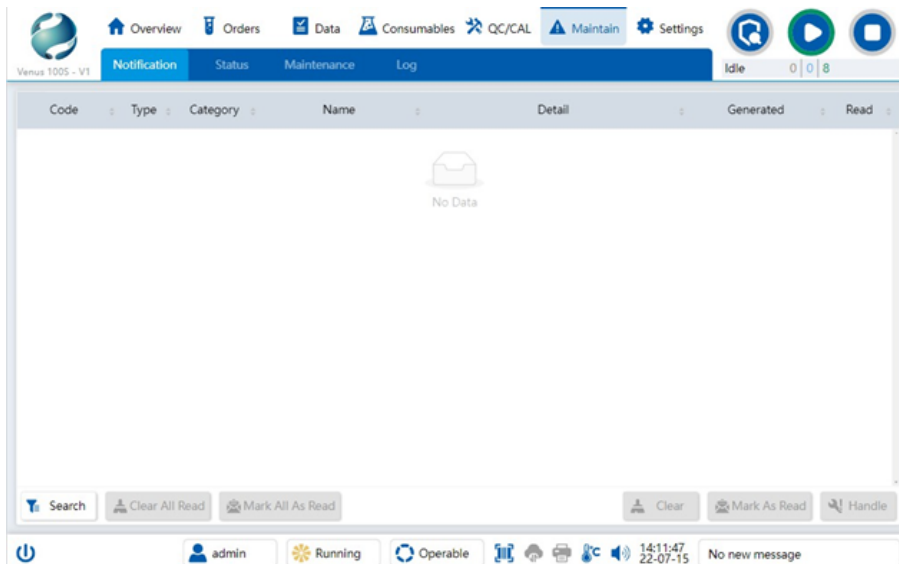

Figure: [Notification] screen under the [Maintain] primary menu item

## Settings

Provides access to configure settings.

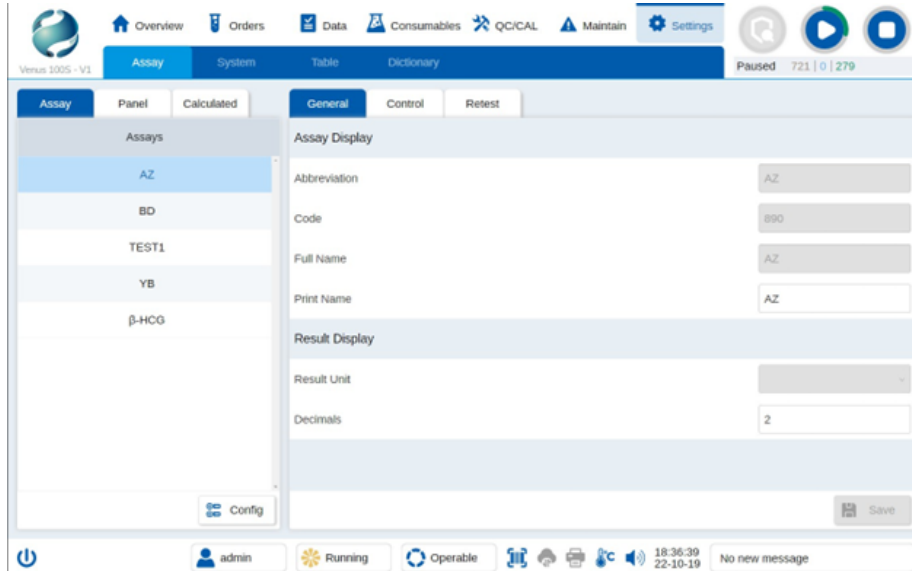







Figure: [Assay] screen under the [Settings] primary menu item

### Analyzer control area

Includes the [Initialize] icon button, the [Start/Pause] icon button, the [Stop] icon button, analyzer status display, tests status/initializing steps display, and time of completion display.









Legend	Name	Function
	[Initialize] icon button	Initializes the analyzer.
	[Start/Pause] icon button	Starts or pauses the sample processing. When analyzer is in the paused state, the sample aspiration will be paused, while the tests that have finished sample aspiration will continue with the process. When in the paused state, samples can be loaded on and unloaded from the sample carousel.
	[Stop] icon button	Stops all component movements and status maintenance (e.g., temperature control).
	Analyzer status display	Displays the current analyzer status. Operating status include: offline, initializing, idle, processing, analyzing, paused, stopped and maintenance.
	Tests status / initialization steps display/ maintenance steps display	-Displays the number of pending tests, running tests, and completed tests after the initialization process. -Displays the current initialization step during the initialization process. -Displays the maintenance steps during the maintenance process.
	Time of completion	Displays the estimated time of completion for all onboard tests.

### Power button

Provides access to turn off, restart, or back up the analyzer computer.

### Shortcut and component status buttons

Displays information of the current user, reagent carousel, sample carousel, LIS status, printer status and system time. The color of the icon will change to yellow or red if the module is busy or any notification is generated.

Legend	Name	Function
	[User] icon button	Displays the current username. Tap this button to log out the current user or log in with another credential.
	[Reagent Carousel] icon button	Displays the reagent carousel status. Tap this button to replace the onboard reagents.
	[Sample Carousel] icon button	Displays the sample carousel status. Tap this button to replace the samples or supplies on the sample carousel.
	[Barcode] icon button	Tap this button to display the barcode input flyout.
	[LIS Status] icon button	Displays the connection and working status of LIS related function.
	[Printer] icon button	Displays the connection and working status of the printer.
	[Temperature] icon button	Displays the temperature status of all modules.
	[Speaker] icon button	Displays and controls the on/off status of the speaker.

## Notification center

Displays the unread notification messages of the current system. Tap this area to show the flyout for all unread messages. Tap the close icon button at the upper right corner of a notification message and the message will be marked as read and be removed from the Notification Center. Tap the message text, and the screen will be navigated to the related notification details screen.

## 1.2 Intended Use

Aurora S-01 System Automatic Chemiluminescence Immunoassay Analyzer is used with the supporting testing reagents. It is used for qualitative or quantitative testing of analytes in blood serum and blood plasma samples from the human body as a way for aided clinical diagnoses.

## WARNING

- Only the reagent kits that have been validated on the analyzer can be used with the analyzer clinically.
- The analyzer can be used together with reagent kits manufactured by Carbon Technologies LLC.

## 1.3 Equipment life and contraindications

Equipment life: The recommended service life is 5 years with the premise that all operation is performed properly following the instruction manual. (Based on the verification tests performed on the key components of the analyzer at 400 tests/day.).

## 1.4 Principles of operation

The analyzer uses chemiluminescence technology, immune response reaction, and magnetic separation technique. By reading and processing the emitted photons of light resulting from chemiluminescent reactions, the



analyzer can facilitate the clinical diagnostic tests of analytes in human serum in a qualitative or quantitative method.

#### 1.4.1 Chemiluminescence principle

Direct chemiluminescence (Aurora S-01 System). This analyzer uses the direct chemiluminescent method based on acridinium ester, which is to mark antigens and antibodies with luminophore markers directly.

#### 1.4.2 Immune reaction methods

Aurora S-01 System supports both competitive immunoassays and sandwich immunoassays.

##### Sandwich immunoassays (Aurora S-01 System)

The sandwich method is a non-competitive assay for the determination of larger antigen or antibody molecules of bivalent or higher. The sandwich immunoassays are divided into the double-antibody sandwich method and the double-antigen sandwich method. If the solid-phase antibodies and the acridine-labeled antibodies are combined with two different antigenic determinants on the antigen molecules in the sample to form a solid-phase antibody-antigen-acridine-labeled antibody immune complex, it is classified as the double-antibody sandwich method. If the solid-phase antigens and the acridine-labeled antigens are combined with the antibody molecules in the sample to form a solid-phase antigen-antibody-acridine-labeled antigen immune complex, it is classified as the double-antigen sandwich method. By adding oxidant pre-trigger solution (H<sub>2</sub>O<sub>2</sub>) and trigger solution (NaOH) to create an alkaline environment, the acridine ester in the complex decomposes and emits photons of light without a catalyst as it relaxes to the ground state. The optical system measures the chemiluminescent emission over a predefined time period to determine the amount of analyte. Since the amount of solid-phase material and acridine ester labeled material in the reaction system is in excess relative to the analyte, the amount of complex formed is proportional to the amount of analyte (within a detectable range).

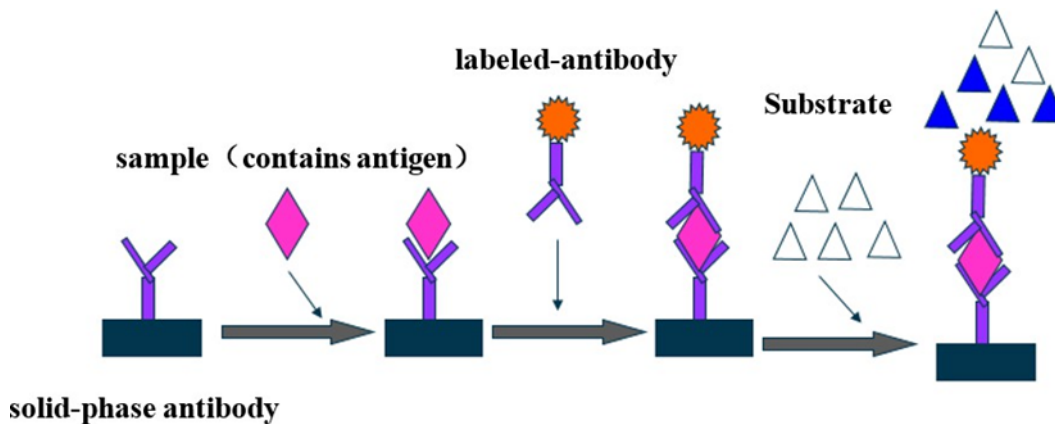

Figure: Sandwich immunoassay

##### Competitive immunoassays (Aurora S-01 System)

The competitive method is generally used to detect small molecule antigens that cannot bind to two antibodies at the same time, but it is also used to detect antibodies. The principle is that the labeled antigen (or antibody) competes with the unlabeled antigen (or antibody) in the sample to bind with the solid-phase antibody (or antigen). In the reaction system, the solid-phase antibody (or antigen) and the labeled antigen (or antibody) are fixed in limited amounts, and the binding site of the former is less than the sum of the molecular amount of the labeled and unlabeled antigens (or antibodies). After the immune reaction, the amount of antigen (or antibody) bound to the solid-phase complex is inversely proportional to the amount of unlabeled antigen (or antibody) in the sample (within a detectable range).

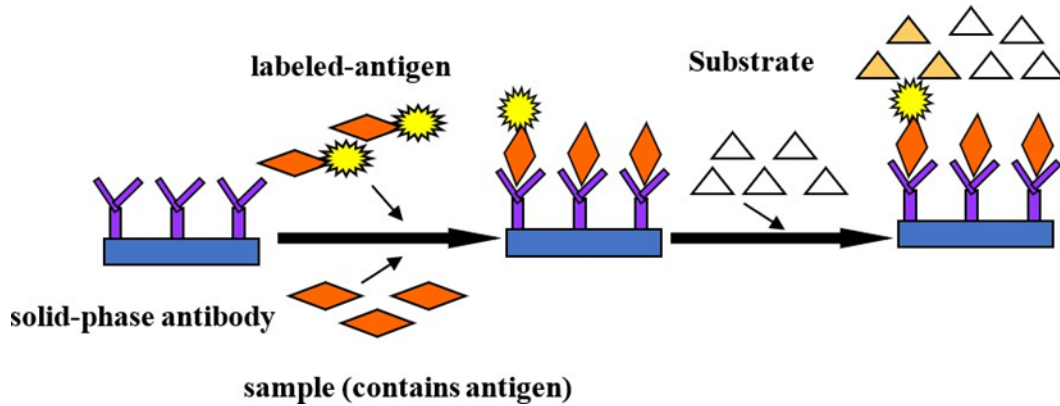

Figure: Competitive immunoassay

### 1.4.3 Magnetic separation technique

Aurora S-01 System uses the magnetic separation technique to separate immune complexes from the other substances. It is a solid-phase extraction technique (SPE) based on magnetic materials as attractants, which usually refer to ferromagnetic oxides, such as magnetite ( $\text{Fe}_3\text{O}_4$ ) and maghemite ( $\gamma\text{-Fe}_2\text{O}_3$ ). The magnetic particle size is generally in the nanoscale. At present, in the field of immunoassay, magnetic beads are usually used as the solid phase. First, a certain antigen or antibody is coated on the surface of the beads. Then allow the magnetic beads to mix or contact with the sample so that the analytes in the sample can react with the antibody or antigen on the beads. Under the effect of the applied magnetic field, the immune complexes and other substances can be separated quickly, and the chemiluminescent emission measurement is performed by the detection system.

## 1.5 Manufacturer Information

### 1.5.1 Manufacturer



Carbon Technologies LLC

### 1.5.2 Address

Innovation Park Muscat (IPM), P.O. Box 92, Al Khoudh 123, Muscat, OMAN.

### 1.5.3 Phone

+968-97058350

### 1.5.4 Email

intl@carbontechnologiesco.com

## 1.6 Technical Support Center

### 1.6.1 Company

Carbon Technologies LLC

### 1.6.2 Registered Address

Innovation Park Muscat (IPM), P.O. Box 92, Al Khoudh 123, Muscat, OMAN.

### **1.6.3 Phone**

+968-97058350

### **1.6.4 Email**

technicalsupport@carbontechnologiesco.com

## **1.7 European Representative**

### **1.7.1 EU Representative**

Obelis s.a.

### **1.7.2 Address**

Bd. Général Wahis 53, B-1030 Brussels, Belgium.

## **Chapter 2 – Specifications**

### **2.1 Software operating specifications**

#### **2.1.1 Computer requirements**

- Processor: 2 GHz Memory: 4 GB RAM Storage: 64 GB
- USB Ports: 2
- Graphics Card: No special requirements

#### **2.1.2 Operating System**

- Debian 10

#### **2.1.3 Network**

When operating, the analyzer is not connected to the WAN, the only connection is with the LAN of the lab/hospital. The network application structure is C/S.

### **2.2 Network security**

#### **2.2.1 Security software**

Debian iptables version 1.8.7 and above.

#### **2.2.2 Data ports**

The external ports of this analyzer are 2 USB ports, 1 LAN port, and 1 serial port. Communication can be conducted using the above interfaces.

#### **2.2.3 Limitation of access**

The user needs to log in to use the software. Username and password can only be numbers and letters.

#### **2.2.4 User access mechanism**

## User identification method

Before using the analyzer software, the user must enter a username and password in order to operate the analyzer or access the related data.

## User groups

There are three user groups: manufacturer engineer, administrator, and operator. The username of the manufacturer engineer is Eng, and the password is customized by the manufacturer. The username of the administrator is Admin, and the password is customized by the administrator. The username of the operator is User, and the user customizes the password.

## Limits of authority

Operators have only general authority to operate the analyzer. The administrators have the authority for user management. The manufacturer engineers have the authority for user management, settings configuration, password resetting to factory default for operators and the administrator, accessing the diagnostic database, performing factory maintenance, etc.

### 2.2.5 Software updates

The analyzer is not connected to WAN while operating. If the software update is requested, a safe and virus-free USB flash drive is required for updating.

## CAUTION

- The user does not need to update the operating software environment. The manufacturer will assign professional personnel to update it when necessary.
- The user does not need to update the security software. The manufacturer will assign professional personnel to update it when necessary.

### 2.2.6 External Devices

To protect customer's interest, any third-party instruments that will be connected with this instrument must meet the relevant compliance and qualification to guarantee the safety of this instrument. Data printing can be achieved by directly connecting to a printer.

## 2.3 Environmental specifications and requirements

- 1- Temperature during operation: 21°C ~ 28°C.
- 2- Relative humidity: ≤ 80% (no condensation).
- 3- Atmospheric pressure: 650hPa ~ 1060hPa.
- 4- Supply voltage: 100-240V~,50/60Hz.
- 5- Altitude: ≤ 3000m.
- 6- Avoid external vibration, noise, electromagnetic field interference, and direct light.
- 7- Have proper electrical grounding.
- 8- Software operation specifications: the same as 2.1
- 9- Size: 67cm×53cm×58cm

## 2.4 Performance requirements

### 2.4.1 Appearance

The appearance of the analyzer should meet the following requirements.

- 1- The appearance of the analyzer should be neat, without cracks or scratches, with clear text and symbol labels.
- 2- The moving parts of the analyzer should be smooth and not jammed with sudden jumps.
- 3- Fasteners should be firmly and reliably connected without loosening.

### 2.4.2 Correctness and repeatability of dispensing volumes

Performed verification tests based on the minimum (5 $\mu$ L) and maximum (100 $\mu$ L) for sample dispensing volume, and the minimum (15 $\mu$ L) and maximum (200 $\mu$ L) for reagent dispensing volume. The results should meet the requirements in the following table.

Table: Requirements for correctness and repeatability of dispensing

Nominal dispensing volume ( $\gamma$ )/ $\mu$ L	Requirements	
	Deviation	Coefficient of variation (CV) %
$\gamma \leq 10$	less than $\pm 1 \mu$ L	$\leq 5$
$10 < \gamma \leq 50$	less than $\pm 10\%$	$\leq 3$
$\gamma > 50$	less than $\pm 5\%$	$\leq 2$

### 2.4.3 Correctness and fluctuation of temperature control in the reaction area

The incubation carousel temperature should be  $37^{\circ}\text{C} \pm 0.5^{\circ}\text{C}$ , and the fluctuation should not exceed  $0.5^{\circ}\text{C}$ .

### 2.4.4 Optical specifications

- 1- Instrument noise

Instrument noise should meet the requirements of the following table.

Table: Instrument noise requirements

Ambient temperature	Dark count rate
$21^{\circ}\text{C} \sim 28^{\circ}\text{C}$	$\leq 200 \text{ RLU/s}$

- 2- Linearity

The linear correlation coefficient ( $r$ ) should be  $\geq 0.99$  when the luminescence is greater than or equal to 3 RLU.

- 3- Repeatability

The coefficient of variation (CV%) should not exceed 5%.

- 4- Stability

The variation of luminescence should not exceed  $\pm 10\%$ .

### 2.4.5 Carryover contamination rate

The carryover contamination rate should be  $\leq 10^{-6}$ .

### 2.4.6 Within-run precision for clinical assays

Coefficient of variation (CV)  $\leq 5\%$ .

## 2.5 Functionality

- 1- Sample capacity of 5 racks (40 sample positions).
- 2- Container capacity of 200 RVs, which can be added at any time.
- 3- Automatic RV arrangement.
- 4- Reagent capacity of 15 reagent racks.
- 5- Obtaining sample information by scanning barcodes or by manual input.
- 6- Obtaining reagent information by scanning barcodes.
- 7- Liquid level detection and aspiration failure warning for pipettor.
- 8- Clot detection for pipettor.
- 9- Crash sensor for pipettor.
- 10- Sample dilution.
- 11- STAT sample processing.
- 12- Liquid level monitoring for external containers.
- 13- Automatic monitoring and insufficient remaining warning for reagent, substrate, diluent, and RVs.
- 14- Obtaining dilution information and substrate information by scanning barcodes.
- 15- Analyzer initialization.
- 16- Pause without affecting tests that have already finished sample aspiration.
- 17- Analyzer operating status monitoring and warning in case of errors.
- 18- Storage of master curve, storage of calibration curve, quality control management, data calculation, data display, data storage, and data printing.
- 19- Reagent refrigeration storage.
- 20- Pre-heating for wash buffers, incubation carousel, washing carousel, and substrate solutions.
- 21- Remote communication.
- 22- One-touch automatic maintenance.

### 2.5.1 Barcode types supported by the built-in barcode reader

#### Linear barcodes

- Code128
- Interleaved 2 of 5
- CODABAR
- Code39
- Code93
- EAN-8
- EAN-13

Among them, Code128, Code93, EAN-8 and EAN-13 requires data integrity check by default. For other barcodes, the data integrity check can be customized.

- 2D barcodes
- PDF417
- Data Matrix

- QR Code

## 2.6 Software features

- 1- The software has a graphical operating interface for test data display, analysis, storage, and printing. The software supports bi-directional data transmission with the LIS server. All the above functions are pre-included and do not require additional installation.
- 2- The complete version of the software and the release version of the software can be viewed in the product information window.

## 2.7 Product model

Table: Product model

Product Model	Aurora S-01 System	
Sample positions	40	
Reagent positions	15	
Fastest speed for one-step assay	120T/h	
Voltage	650VA	
Cabinet	None	
Version	V1	
Software Components	Name	Automatic Chemiluminescence Immunoassay Analyzer

## Chapter 3 - Installation

### 3.1 Installation tips

After purchasing the Venus 100 Series Automatic Chemiluminescence Immunoassay Analyzer, please inform the manufacturer or the authorized local distributor. The manufacturer or the authorized local distributor will schedule the installation and calibration service by professional personnel, as well as provide operation training for the designated users. Do not disassemble the instrument without permission, otherwise, all consequences will be at the cost of the user.

### 3.2 Installation requirements

- 1- Indoor use.
- 2- Pollution degree 2.
- 3- Level ground surface with an inclination of less than 1/200.
- 4- Strong and steady floor to withstand a weight of at least 200kg at the installation location.
- 5- Level and flat operating table surface to withstand a weight of at least 200kg. The table height should be in the range of 700mm-800mm and the table surface area size should be no less than 680mm x 550mm.
- 6- Dust-free environment with good ventilation. Avoid direct sunlight. No corrosive or flammable gases. No heat or wind sources. No interference from mechanical vibration or electromagnetic field.
- 7- Installation location and space should be convenient for relevant personnel to do maintenance for the analyzer.
- 8- The socket and power cord for the analyzer power supply must have a protective ground wire and the analyzer needs to have a good ground connection.
- 9- A designated container or drainage system in hospitals is required to receive the liquid waste discharged from the instrument. The liquid waste container or drainage system needs to have a backflow prevention

mechanism. The liquid waste generated by the analyzer needs to be discharged into a specific drainage system that complies with the facility's regulations for the disposal of hazardous waste.

**NOTE:** See Table: Analyzer weight for the weight of the analyzer.

Table: Analyzer weight

Model	Weight
Aurora S-01 System	80 kg

### 3.3 Installation Process

#### 3.3.1 Analyzer unboxing and installation

- 1- As shown in the figures below, on the outside of the wooden box, check whether the transportation safety labels indicate appropriate handling during transportation.



Figure: Tip indicator label



Figure: Shock indicator label

- 2- The analyzer is packaged as shown below. Use tools such as a utility knife to open the packing carton and remove the protective foam. Use an Allen wrench to remove the fasteners, and take out the analyzer. Choose an appropriate installation location that meets the installation requirements, and place the analyzer on a table surface that meets the requirements.





Figure: Packaging of the analyzer



Figure: Analyzer

### CAUTION

- The instrument is so heavy that it requires no less than 2 adults to carry it, including engineers.
- To ensure adequate cooling and ventilation, as well as access for maintenance and cleaning, the analyzer should maintain a distance of at least 50cm from the wall or other equipment on all sides.

- Do not install the analyzer at a location where it is difficult to access the disconnection device (power switch, power input socket, plug).
- 3- Check whether the packaging of the accessory box is intact. Proceed to open the accessory box if no damage exists. Count and check the items listed in the packing list to ensure that all parts and accessories are present without damage. Installation can be continued next if all items are confirmed. If any item is missing, please contact the manufacturer or local distributor in time.



Figure: Accessories box

### 3.3.2 Connections

- 1- Take out the accessories from the accessory box carefully.
- 2- Confirm that the main power rocker switch is in the "power off" state  $\text{O}$  before connecting the power cord.



Figure: Power outlet location

- 3- Take out the silicone tubing, tubing connectors, and liquid level monitoring sensors from the accessory box. Connect the tubing and sensors according to the symbols on the left side of the analyzer and position the end of the tubing into corresponding external containers, as shown in the figure below.



Figure: External container tubing connection location

### CAUTION

L1, L2, and L3 sequentially represent liquid level monitoring sensors for wash buffer, cleaning solution and liquid waste.

P1, P2, and P3 sequentially represent tubing connectors for wash buffer (2 tubing), cleaning solution (1 tubing), and liquid waste (2 tubing).

- 4- Open the door of the RV waste and substrate compartment. Check whether the substrate tubing is properly connected. Check whether there are ruptures or leaks in the tubing. After a biohazard bag is installed on the RV waste container, place it into the waste compartment.



Figure: RV waste container compartment



Figure: Substrate compartment

- 5- Install the barcode reader (auxiliary device). (Please refer to the installation instruction of the barcode reader).
- 6- Load RVs: Take out the RVs from the accessory box, open the cover of the RV hopper, and pour the RVs into the RV hopper.

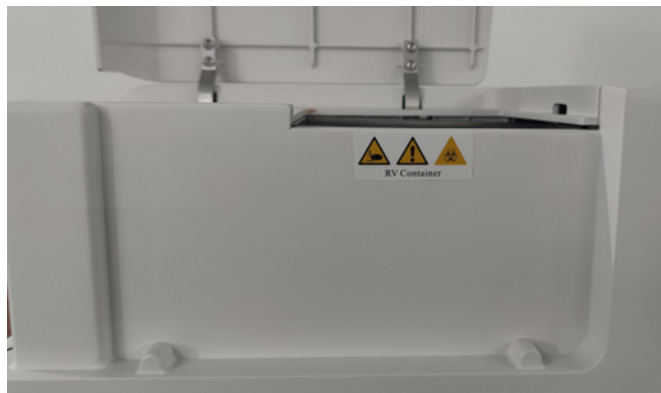

Figure 4.9 RV hopper

- 7- Check the above steps to confirm that all connections are correctly done.

### CAUTION

- Check the above installation steps thoroughly. Only after the installation is confirmed correctly done, the analyzer can start running.
- The USB ports of the analyzer are reserved for connection with the hand-held barcode reader, printer, etc. The serial port of the analyzer is reserved for LIS data transmission. The LAN port of the analyzer is reserved for LIS data transmission. The external circuit insulation of the analyzer should be not less than 1MΩ.
- External devices (hand-held barcode reader, printer, etc.) connected with the analyzer shall not cause reduction of safety or performance of the analyzer.

## Chapter 4 - Analyzer configuration

### 4.1 Assay configuration

#### 4.1.1 Assays

Assays displays the assays configured as current assays on this analyzer. Only after being configured on the analyzer, can assays be displayed in any assay-related fields on the software screens, or be used for test orders and procedures.

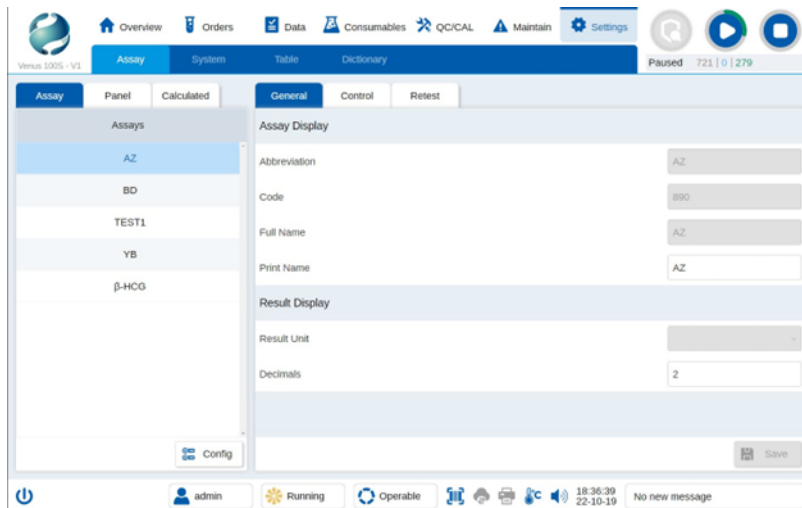

Figure: [Assay] configuration

#### Add assays to and remove assays from the current assays

Assay configuration requires the administrator access level.

- 1- On the main menu, tap [Settings].
- 2- On the submenu, tap [Assay].
- 3- Under the [Assays] list, tap the [Config] button to display the [Configure Current Assays] window.
- 4- In the [Configure Current Assays] window:
  - From the [All Pre-Configured Assays] list, select assays that need to be added, and tap the [Add] button.
  - From the [Current Assays] list, select assays that need to be removed, and tap the [Remove] button.
- 5- In the [Configure Current Assays] window:
  - Tap the [OK] button to save the changes and close the window.
  - Tap the [Cancel] button to close the window without saving.

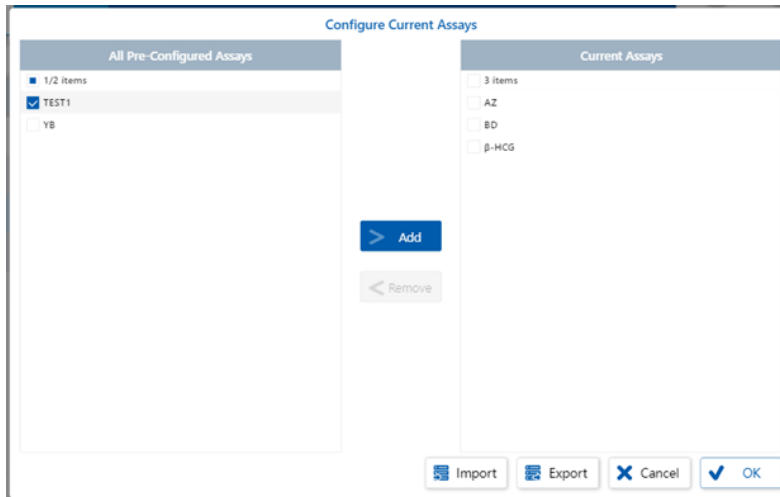

Figure: [Configure Current Assays] window

### Configure control rules

Before the QC tests start, the QC rules need to be set for the assay. If no QC rule is set, the user can still create QC test orders, but the analyzer will not perform the QC tests. Setting the control rules requires the administrator access level and the analyzer in [Offline] and [Idle] states.

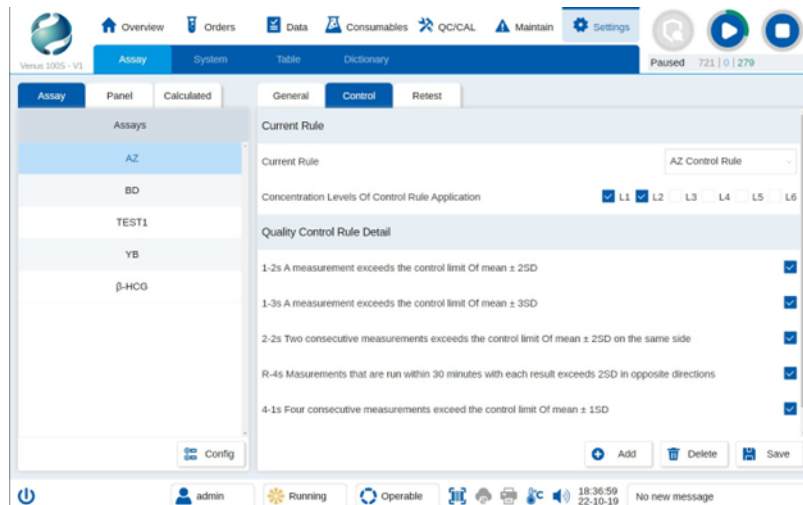

Figure: [Control] rule configuration

Table: QC result flags and description

Flag	Description
1-2s	A measurement exceeds the control limit of mean $\pm$ 2SD
1-3s	A measurement exceeds the control limit of mean $\pm$ 3SD
2-2s	Two consecutive measurements exceed the control limit of mean $\pm$ 2SD on the same side
R-4s	Measurements that are run within 30 minutes with each result exceeds 2SD in the opposite directions
4-1s	Four consecutive measurements exceed the control limit of mean $\pm$ 1SD
10-x	10 consecutive measurements fall on the same side of the mean

### Add a control rule

- 1- On the main menu, tap [Settings].

- 2- On the submenu, tap [Assay].
- 3- From the left tabs on the [Assay] screen, select [Assay].
- 4- From the [Assays] list, select the assay for which the control rule needs to be added.
- 5- From the right tabs on the [Assay] screen, select [Control].
- 6- Under the [Control] tab area, tap the [Add] button to display the [Add Quality Control Rule] window.
- 7- In the [Add Quality Control Rule] window, enter the control rule name in [Quality Control Rule Name] text box, and tap the [OK] button.
- 8- In the [Concentration Levels of Control Rule Application] checkboxes, check the concentration levels to which the rule will be applied.
- 9- In the [Quality Control Rule Detail] area, check one or more control rules which need to be used.
- 10- Under the [Control] tab area, tap the [Save] button to save and apply the QC rule.

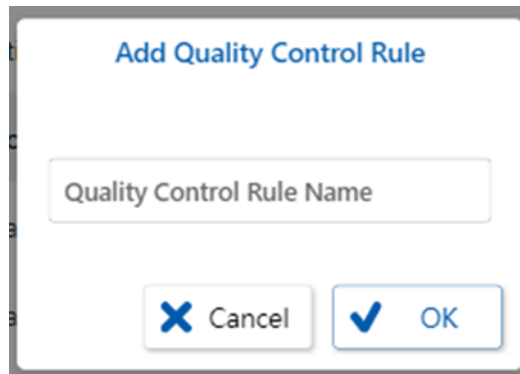

Figure: [Add Quality Control Rule] window

### Modify a control rule

- 1- On the main menu, tap [Settings].
- 2- On the submenu, tap [Assay].
- 3- From the left tabs on the [Assay] screen, select [Assay].
- 4- From the [Assays] list, select the assay for which the control rule needs to be modified.
- 5- From the right tabs on the [Assay] screen, select [Control].
- 6- From the [Current Rule] drop-down list, select the rule to be modified.
- 7- In the [Concentration Levels of Control Rule Application] checkboxes, change the concentration levels to which the rule will be applied.
- 8- In the [Quality Control Rule Detail] area, modify selections of the control rules which need to be used.
- 9- Under the [Control] tab area, tap the [Save] button to save and apply the QC rule.

### Delete a control rule

- 1- On the main menu, tap [Settings].
- 2- On the submenu, tap [Assay].
- 3- From the left tabs on the [Assay] screen, select [Assay].
- 4- From the [Assays] list, select the assay for which the control rule needs to be deleted.
- 5- From the right tabs on the [Assay] screen, select [Control].
- 6- From the [Current Rule] drop-down list, select the rule to be deleted.

- 7- Under the [Control] tab area, tap the [Delete] button.
- 8- When a confirmation message is displayed, tap the [OK] button to delete the current QC rule.

### Configure retest rules

When the specimen test procedure is performed, the analyzer will check if the result meets the criteria configured in the retest rules of an assay. When the test results meet the retest rule, automated rerun order will be created and performed according to the test options set in the retest rule.

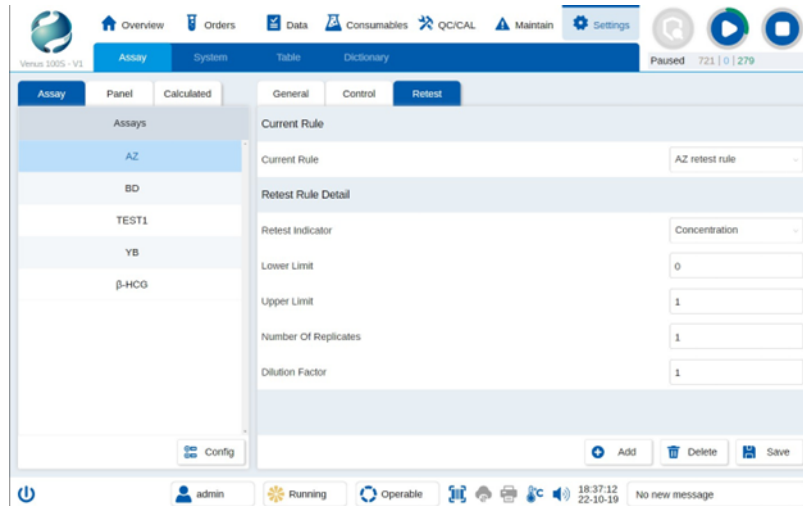

Figure: [Retest] rule configuration

### Add a retest rule

- 1- On the main menu, tap [Settings].
- 2- On the submenu, tap [Assay].
- 3- From the left tabs on the [Assay] screen, select [Assay].
- 4- From the [Assays] list, select the assay for which the retest rule needs to be added.
- 5- From the right tabs on the [Assay] screen, select [Retest].
- 6- Under the [Retest] tab area, tap the [Add] button to display the [Add Retest Rule] window.
- 7- In the [Add Retest Rule] window, enter the retest rule name in [Retest Rule Name] text box, and tap the [OK] button.
- 8- In the [Retest Rule Detail] area:
  - Select from the [Retest Indicator] drop-down list to be [Concentration] or [RLU]
  - In the [Lower Limit], enter a low value under which the retest rule will be activated.
  - In the [Upper Limit], enter a high value above which the retest rule will be activated.
  - In the [Number of Replicates], enter the maximum number of retest orders that can be generated.
  - In the [Dilution Factor], enter the dilution factor for the retest test.
  - Under the [Retest] tab area, tap the [Save] button to save and apply the retest rule.



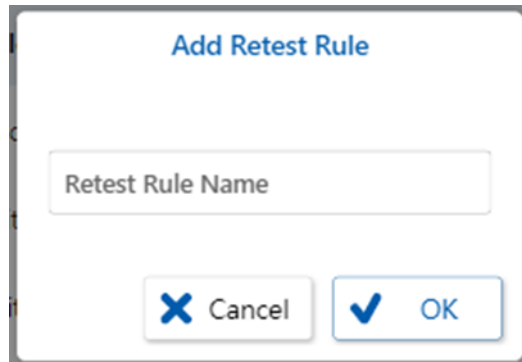

Figure: [Add Retest Rule] window

### Modify a retest rule

- 1- On the main menu, tap [Settings].
- 2- On the submenu, tap [Assay].
- 3- From the left tabs on the [Assay] screen, select [Assay].
- 4- From the [Assays] list, select the assay for which the retest rule needs to be modified.
- 5- From the right tabs on the [Assay] screen, select [Retest].
- 6- From the [Current Rule] drop-down list, select the rule to be modified.
- 7- In the [Retest Rule Detail] area, modify the retest rule detail.
- 8- Under the [Retest] tab area, tap the [Save] button to save and apply the retest rule.

### Delete a retest rule

- 1- On the main menu, tap [Settings].
- 2- On the submenu, tap [Assay].
- 3- From the left tabs on the [Assay] screen, select [Assay].
- 4- From the [Assays] list, select the assay for which the retest rule needs to be deleted.
- 5- From the right tabs on the [Assay] screen, select [Retest].
- 6- From the [Current Rule] drop-down list, select the rule to be deleted.
- 7- Under the [Retest] tab area, tap the [Delete] button.
- 8- When a confirmation message is displayed, tap the [OK] button to delete the current retest rule.

### 4.1.2 Assay panel

The assay panel provides an option to add assay tests for sample orders more conveniently when the assays are often used together as a group. The user can set up an assay panel that consists of this kind of constituent assays and later use it by tapping the assay panel button. The constituent assays can be selected from the assays currently configured on this analyzer. Calculated assays are not included in the constituent assays.

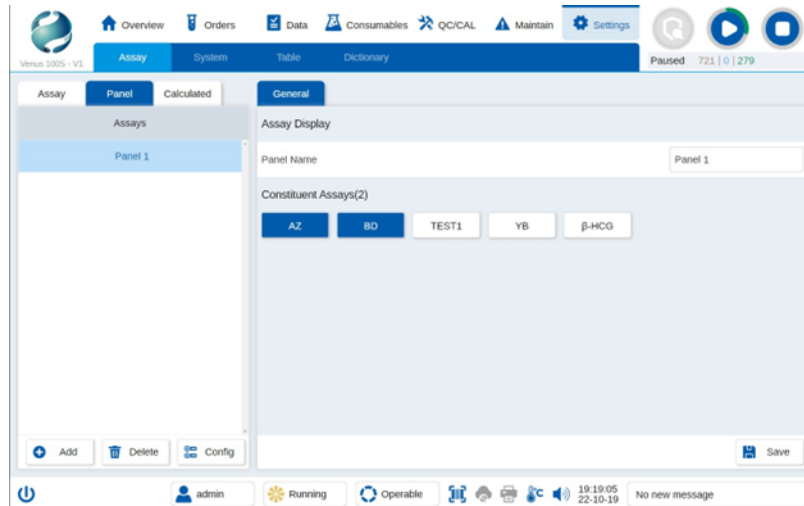

Figure: [Panel] configuration

### Add assay panel

- 1- On the main menu, tap [Settings].
- 2- On the submenu, tap [Assay].
- 3- From the left tabs on the [Assay] screen, select [Panel].
- 4- Under the [Assays] list, tap the [Add] button.
- 5- In the [General] tab area:
  - In the [Panel Name] text box, enter the name of the assay panel.
  - In the [Constituent Assays], select the current assays included in the assay panel.
- 6- Under the [General] tab area, tap the [Save] button to save the assay panel.

### Modify assay panel

- 1- On the main menu, tap [Settings].
- 2- On the submenu, tap [Assay].
- 3- From the left tabs on the [Assay] screen, select [Panel].
- 4- From the [Assays] list, select the assay panel to be modified.
- 5- In the [General] tab area, modify the assay panel detail.
- 6- Under the [General] tab area, tap the [Save] button to save the changes.

### Delete assay panel

- 1- On the main menu, tap [Settings].
- 2- On the submenu, tap [Assay].
- 3- From the left tabs on the [Assay] screen, select [Panel].
- 4- From the [Assays] list, select the assay panel to be deleted.
- 5- Under the [General] tab area, tap the [Delete] button.
- 6- When a confirmation message is displayed, tap the [OK] button to delete the selected assay panel.

### 4.1.3 Calculated assays

Calculated assays are assays that are mathematically calculated based on one or more assay results to produce clinically relevant results.

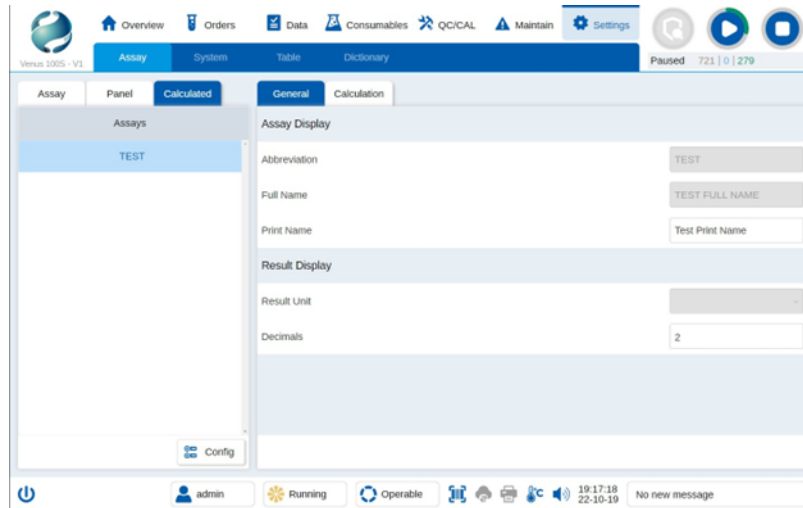

Figure: [Calculated] assay configuration

#### View calculated assays

- 1- On the main menu, tap [Settings].
- 2- On the submenu, tap [Assay].
- 3- From the left tabs on the [Assay] screen, select [Calculated].
- 4- From the [Assays] list, select the calculated assays to be viewed.
- 5- From the right tabs on the [Assay] screen :
  - Select [General] to view the general information of the calculated assay.
  - Select [Calculation] to view the calculation formula and the assays which participate in the calculation.

#### Add calculated assay

If additional calculated assays need to be added, please contact the field service engineers.

### 4.2 System configuration

This section describes the definition of all setting options in the [System] screen under the [Settings] main menu. In default, all settings take effect immediately after saving if they are not specified otherwise.

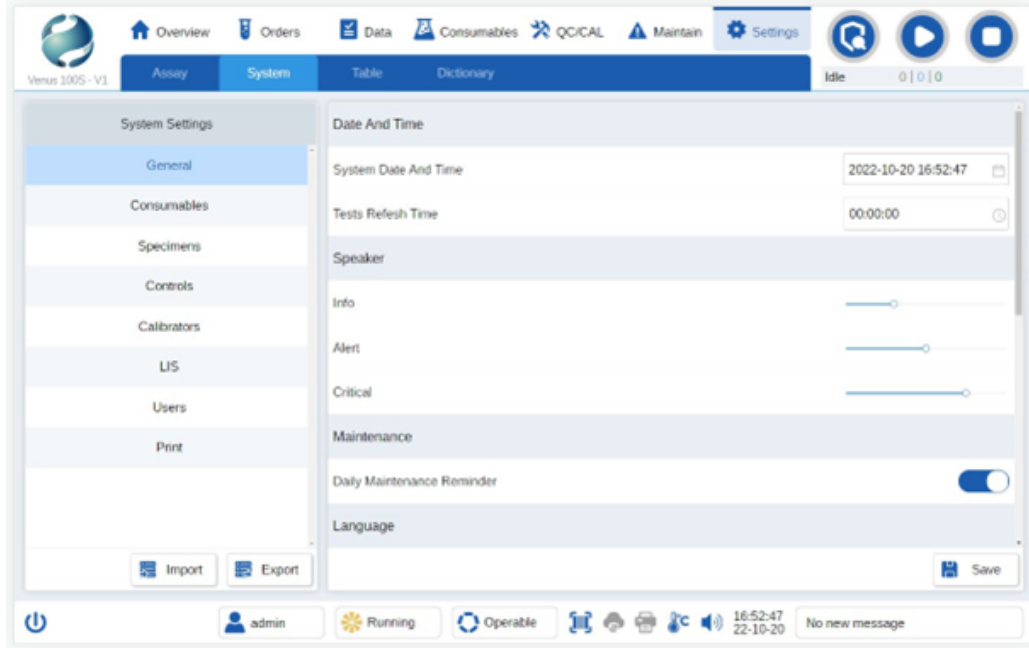

Figure: [System] configuration

## 4.2.1 General settings

### System date and time

The user can view and change the system date and time of the analyzer. System date and time can only be modified when the analyzer is in [Offline] and [Idle] state.

### Tests refresh time

Test refresh time refers to the time of a day when all completed tests before this time point are archived automatically. The analyzer displays all tests after this time point within 24 hours. When a test is in [Pending] or [Running] state, it will ignore the 24-hour time range and be kept on the screens as long as the analyzer has not been turned off yet.

### Info volume

The user can adjust the speaker volume for information notifications by sliding the volume bar.

### Alert volume

The user can adjust the speaker volume for alert notifications by sliding the volume bar.

### Critical volume

The user can adjust the speaker volume for critical notifications by sliding the volume bar.

### Daily maintenance reminder

If the [Daily Maintenance Reminder] switch is on, when the user shuts down the analyzer without performing daily maintenance on the day of, the user will be prompted to decide whether a daily maintenance procedure needs to be performed. Otherwise, the analyzer will shut down directly without asking.

### **System language**

The user can select the language of the software interface from the [System Language] drop-down list.

### **Range specifier**

Range specifier is used within a range to connect two values, as the word "to". For example, when "-" is used as the range specifier to represent number range from 2 to 8, the range will be specified as "2-8".

### **Range delimiter**

Range delimiter is used to separate from one range from another. For example, when ";" is used as the range delimiter, range A and range B will be specified as "range A, range B".

### **Assay columns per row**

The user can customize the assay columns per row displayed in the orders screen in the sample editing area by selecting from the drop-down list.

### **Assay panel columns per row**

The user can customize the assay panels per row displayed in the orders screen in the sample editing area by selecting from the drop-down list.

### **Reagent columns per row**

The user can customize the reagent columns per row displayed in the orders screen in the sample editing area by selecting from the drop-down list.

### **Assays displayed in orders screens**

The user can customize the assays displayed in the orders screen to be the [Configured] assays or the [Onboard] assays by selecting from the drop-down list.

## **4.2.2 Consumables settings**

### **Quality Control Interval**

Quality control interval refers to the amount of time in hours that the quality control is valid. This value takes part in the assessment of quality control status.

- If the difference between the current system time and the successful quality control result time is larger than the quality control interval, the reagent control status will change to [QC Expired].
- If the difference between the current system time and the successful quality control result time is smaller than or equal to the quality control interval, the reagent control status stays [QC OK].

### **Usable while calibration not OK**

If this switch is on, the reagent can still be used for assay test while the reagent calibration is not in [Calibration OK] status.

### **Reagent low notification**

The reagent low notification refers to the number of tests remaining lower than which the [Remaining test count below notification value] notification is generated. If the value is set to 0, this notification will not be generated.

### **Reagent open-bottle stability**

The reagent open-bottle stability refers to the amount of time in days that the reagent stability is valid after opening. When the reagent is loaded on the analyzer, the countdown will start with this value. When the countdown ends, the [Reagent open-bottle stability exceeded] notification will be generated.

### **Default time range for display of historical reagents**

This time range refers to the maximum time difference in days between the date opened and the current date of the reagents displayed by default in the [Historical Reagents] window.

### **Substrate open-bottle stability**

The substrate open-bottle stability refers to the amount of time in days that the substrate stability is valid after opening. When the substrate is loaded on the analyzer, the countdown will start with this value. When the countdown ends, the [Supply open-bottle stability exceeded] notification will be generated.

### **Diluent open-bottle stability**

The diluent open-bottle stability refers to the amount of time in days that the diluent stability is valid after opening. When the diluent is loaded on the analyzer, the countdown will start with this value. When the countdown ends, the [Supply open-bottle stability exceeded] notification will be generated.

### **Enhanced cleaning solution open-bottle stability**

The enhanced cleaning solution open-bottle stability refers to the amount of time in days that the enhanced cleaning solution stability is valid after opening. When the enhanced cleaning solution is loaded on the analyzer, the countdown will start with this value. When the countdown ends, the [Supply open-bottle stability exceeded] notification will be generated.

### **Substrate remaining notification**

The substrate remaining notification is the number of tests below which a [Remaining test count below notification value] notification will be generated. If the value is set to 0, this notification will not be generated.

### **Diluent remaining notification**

The diluent remaining notification is the amount of diluent in milliliter below which a [Remaining test count below notification value] notification will be generated. If the value is set to 0, this notification will not be generated.

### **Enhanced cleaning solution remaining notification**

The enhanced cleaning solution remaining notification is the amount of diluent in milliliter below which a [Remaining test count below notification value] notification will be generated. If the value is set to 0, this notification will not be generated.

### **RV remaining notification**

The RV remaining notification is the number of reaction vessels below which a [Remaining test count below notification value] notification will be generated. If the value is set to 0, this notification will not be generated.

### **RV waste notification**

The RV waste notification is the number of used RVs in the waste container above which a [Remaining test count below notification value] notification will be generated. If the value is set to 0, this notification will not be generated.

## **4.2.3 Specimens settings**

### **Default specimen type**

The default specimen type will be automatically selected in the [Specimen Type] drop- down list when manually adding a new specimen.

### **Default specimen container**

The default specimen container will be automatically selected in the [Container] drop- down list when manually adding a new specimen.

### **Automatic sequence number**

If this switch is on, the analyzer will automatically generate a sequence number for the new specimen according to [Auto Sequence Number Format] when adding specimens manually.

### **Auto sequence number format**

The auto sequence number format consists of [Prefix], [Start Number], and [Suffix]. The [Prefix] and [Suffix] are strings, which can be left blank, and the [Start Number] is a number. The sequence number will increment by one starting from the [Start Number] and add the [Prefix] before and [Suffix] after the [Start Number].

### **Allow duplicate sample ID**

If this switch is off, an SID check will be performed when new orders are created. If the same SID already exists, the new order is not allowed to be saved and the user will be informed about the SID check failure. If this switch is on, multiple orders with the same SID are allowed.

### **Default primary keyword for sample order selection**

This refers to the default option selection keyword when multiple samples are partially matched after the sample scanning process. The options include [SID], [Rack Position] and [Carousel Position].

### **Result value below the lower normal reference range**

This flag will be attached to the results that are below the lower normal reference range.

### **Result value above the upper normal reference range**

This flag will be attached to the results that are above the upper normal reference range.

### **Result value below the lower critical reference range**

This flag will be attached to the results that are below the lower critical reference range.

### **Result value above the upper critical reference range**

This flag will be attached to the results that are above the upper critical reference range.

## **4.2.4 Controls settings**

### **Replicates of test per concentration level**

It refers to the minimum replicates of the control test for each concentration level. When creating QC test orders, the analyzer will compare the number of tests with this value. Orders are not allowed to be saved if the number of tests is less than this value.

### **Default time range for display**

It refers to the maximum date difference in days between the system date and the [Opened Date] of the controls displayed in the [Controls / Controls Combinations] list in the [Controls] screen under the [QC/CAL] main menu.

### **Controls and associated assays**

This table lists all controls configured on this analyzer with the concentration levels of each assay that the control can be used for. After the control and the associated assays are added, the control will be added to the [Name] drop-down list in the [Edit Control] window. The associated assay with the concentration levels will be listed in [Concentration Data] for the user to fill in the detailed information.

### **Add a control and its associated assay**

- 1- On the main menu, tap [Settings].
- 2- On the submenu, tap [System].
- 3- From the [System Settings] list, select [Controls].
- 4- On the [Controls] settings screen, tap the [Add] button below to display the [Edit Associated Assays] window.
- 5- In the [Edit Associated Assays] window:
  - In the [Control Name] text box, Enter the control name.
  - In the [Associated Assay] module, select assays associated with the control.
  - In the [Concentration Levels] table, check the concentration levels for each assay.
  - Tap the [OK] button.

### **Modify a control and its associated assay**

- 1- On the main menu, tap [Settings].
- 2- On the submenu, tap [System].
- 3- From the [System Settings] list, select [Controls].
- 4- On the [Controls] settings screen
  - Select the control to be modified from the [Controls and Associated Assays] table.
  - Tap the [Modify] button below to display the [Edit Associated Assays] window.



- 5- In the [Edit Associated Assay] window:
  - Modify the [Control Name], [Associated Assay], or the [Concentration Levels] table.
  - Tap the [OK] button.

#### **Delete a control and its associated assay**

- 1- On the main menu, tap [Settings].
- 2- On the submenu, tap [System].
- 3- From the [System Settings] list, select [Controls].
- 4- On the [Controls] settings screen
  - Select the control to be deleted from the [Controls and Associated Assays] table.
  - Tap the [Delete] button.
- 5- When a confirmation message is displayed, tap [OK].

#### **4.2.5 Calibrators settings**

##### **Replicates of test per concentration level**

It refers to the minimum replicates of the calibration test for each concentration level. When creating calibration test orders, the analyzer will compare the number of tests with this value. Orders are not allowed to be saved if the number of tests is smaller than this value.

##### **Default time range for display**

It refers to the maximum date difference in days between the system date and the [Opened Date] of the calibrators displayed in the [Calibrators] list in the [Calibrators] screen under the [QC/CAL] main menu.

##### **Calibrators and associated assays**

This table lists all calibrators configured on this analyzer with the concentration levels of each assay that the calibrator can be used for. After the calibrator and the associated assay are added, the calibrator will be added to the [Name] drop-down list in the [Edit Calibrator] window. The associated assay with the concentration levels will be listed in [Concentration Data] for the user to fill in the detailed information.

##### **Add a calibrator and its associated assay**

- 1- On the main menu, tap [Settings].
- 2- On the submenu, tap [System].
- 3- From the [System Settings] list, select [Calibrators].
- 4- On the [Calibrators] settings screen, tap the [Add] button below to display the [Edit Associated Assays] window.
- 5- In the [Edit Associated Assays] window:
  - In the [Calibrator Name] text box, Enter the calibrator name.
  - In the [Associated Assays] module, select the assay associated with the calibrator.
  - In the [Concentration Levels] table, check the concentration levels for each assay.
  - Tap the [OK] button.

##### **Modify a calibrator and its associated assay**

- 1- On the main menu, tap [Settings].
- 2- On the submenu, tap [System].
- 3- From the [System Settings] list, select [Calibrators].
- 4- On the [Calibrators] settings screen
  - Select the calibrator to be modified from the [Calibrators And Associated Assays] table.
  - Tap the [Modify] button below to display the [Edit Associated Assays] window.
- 5- In the [Edit Associated Assays] window:
  - Modify the [Calibrator Name], [Associated Assay], or the [Concentration Levels] table.
  - Tap the [OK] button.

#### **Delete a calibrator and its associated assay**

- 1- On the main menu, tap [Settings].
- 2- On the submenu, tap [System].
- 3- From the [System Settings] list, select [Calibrators].
- 4- On the [Calibrators] settings screen
  - Select the calibrator to be deleted from the [calibrators and associated assays] table.
  - Tap the [Delete] button.
- 5- When a confirmation message is displayed, tap [OK].

### **4.2.6 LIS settings**

#### **Basic LIS parameters**

The analyzer supports bi-directional communication with the host, i.e., the analyzer can send test results and patient information to the host as well as obtain test information from the host. The user should configure LIS settings properly in order to connect to the host.

#### **LIS communication**

If [LIS Communication] is on, the analyzer will automatically establish the connection with the host after startup. Otherwise, any function that is related to communication will be disabled.

#### **Character encoding**

Character encoding format options include [UTF-8], [ASCII] and [Unicode]. The encoding format should be the same as the encoding format used by the host.

#### **Reconnection interval**

The reconnection interval refers to the amount of time in seconds for the analyzer to try to re-establish the connection with the host when the [LIS Communication] switch is on but the analyzer is disconnected from the host.

#### **Analyzer identifier**

The user can customize the identifier of this analyzer, and this identifier will be sent to the host as the identifier of the analyzer in the communication.

## Transmission mode

The transmission mode options include [Automatic], [Released] and [Manual].

- In [Automatic] mode, the test results will be automatically transferred to the host once the test status changes to [Completed]. If an assay has been rerun or multiple tests are ordered for one assay, all results will be transmitted to the host.
- In [Released] mode, the test results will be automatically transmitted to the host once the [Released] status of the test changes to "✓".
- In [Manual] mode, the test will be automatically transmitted to the host when the user taps the [Transmit] button.

## Transmit results with exceptions

If this switch is on, the test results with [Flags] will be transmitted to the host. Otherwise, those results will be skipped when transmitting results.

## Transmission timeout interval

The transmission timeout interval refers to the amount of time in seconds for the analyzer to wait for the host response after each message is sent. If the analyzer does not receive a response message within this time limit, a timeout notification message will be generated.

## Retransmission

If this switch is on, the analyzer will send the message whose response message is not received for a second time before the timeout notification message is generated. Otherwise, the analyzer will only send each message once and continue to send the next message upon transmission timeout.

## Communication type

- Communication type options include [TCP/IP] and [Serial]. The user can select the communication type according to the physical connection port used for communication.
- When [TCP/IP] option is selected, the [TCP/IP Communication Settings] should be configured.
- When [Serial] option is selected, the [Serial Communication Settings] should be configured.

## Communication mode

Communication mode options include [Unidirectional] and [Bidirectional]. The user can select the communication mode according to the facility requirements and the host communication mode.

- Under the [Unidirectional] communication mode, messages will only be transmitted from the analyzer to the host with test results.
- Under the [Bidirectional] communication mode, messages will be transmitted from the host to the analyzer with the test orders and from the analyzer to the host with test results.

## TCP/IP network connection parameters

### LIS service IP

The IP address of the LIS should be provided by the LIS service provider.

**LIS service port**

The port number of the LIS should be provided by the LIS service provider.

**Analyzer IP**

The IP address of the analyzer should be set according to the IP address provided by the IT administrator of the facility.

**Analyzer Subnet Mask**

The subnet mask of the analyzer should be set according to the subnet mask provided by the IT administrator of the facility.

**Default gateway**

The default gateway of the analyzer should be set according to the default gateway provided by the IT administrator of the facility.

**Serial port connection parameters****Serial port**

The [Serial Port] drop-down list will display all connected COM ports. The user should select the COM port used for communication with the host.

**Data bit**

The [Data Bit] options include [5], [6], [7], and [8]. The data bit needs to be the same as the data bit of the host, which should be provided by the IT administrator of the facility.

**Stop bit**

The [Stop Bit] options include [1], [1.5], and [2]. The stop bit needs to be the same as the stop bit of the host, which should be provided by the IT administrator of the facility.

**Baud rate**

The [Baud Rate] options include [300], [1200], [2400], [4800], [9600], [19200], [38400], [57600] and [115200]. The baud rate needs to be the same as the baud rate of the host, which should be provided by the IT administrator of the facility.

**Parity**

The [Parity] options include [None], [Odd], [Even], [Mark], and [Space]. The parity needs to be the same as the parity of the host, which should be provided by the IT administrator of the user's organization.

**Assay test code**

Before data transmission starts, assay test codes should be set for each assay on both the host side and the analyzer side as the identifiers in communication.

## Ignore unconfigured assay test code

If this switch is on, the unrecognized assay test code in the response message from the host will be ignored. Otherwise, a message will be generated to notify the user about the unrecognized assay codes.

## Test codes table

The test code for each assay should be the same as the assay code on the host. The assays displayed in this table can be configured by tapping the [Config] button on the [Assay] screen under the [Settings] main menu.

### 4.2.7 Users settings

On the [Users] settings screen, the operator can view all users that have been created on the system with different access levels. Local users are divided into [Operator] and [Admin] user groups. Users of the [Admin] user group can add a new user, change the password or user group for current users, or delete users. Users of the [Operator] group can only change the current user's password.

#### View all authorized users

- 1- On the main menu, tap [Settings].
- 2- On the submenu, tap [System].
- 3- From the [System Settings] list, select [Users].
- 4- All user names and their user group will be displayed in the user list on the right.

#### Add a user

- 1- On the main menu, tap [Settings].
- 2- On the submenu, tap [System].
- 3- From the [System Settings] list, select [Users].
- 4- Below the user list on the right, tap the [Add] button to display the [Edit User] window.
- 5- In the [Edit User] window:
  - Enter [Username], [Password], [Confirm Password] and select [User Group].
  - Tap the [Save] button.
- 6- In the user list, the new user will be displayed.

#### Change user password

- 1- On the main menu, tap [Settings].
- 2- On the submenu, tap [System].
- 3- From the [System Settings] list, select [Users].
- 4- From the user list on the right, select the user to be modified.
- 5- Below the user list on the right, tap the [Change Password] button to bring up the [Edit User] window.
- 6- In the [Edit User] window:
  - Modify [Password] and [Confirm Password].
  - Tap [Save] to save the changes.

## Change user group

- 1- On the main menu, tap [Settings].
- 2- On the submenu, tap [System].
- 3- From the [System Settings] list, select [Users].
- 4- From the user list on the right, select the user to be modified.
- 5- Below the user list on the right, tap the [Change Group] button to bring up the [Edit User] window.
- 6- In the [Edit User] window:
  - Modify [User Group].
  - Tap [Save] to save the changes.

## Delete a user

- 1- On the main menu, tap [Settings].
- 2- On the submenu, tap [System].
- 3- From the [System Settings] list, select [Users].
- 4- From the user list on the right, select the user to be deleted.
- 5- Below the user list on the right, tap the [Delete] button to display the deletion confirmation window.
- 6- Tap the [OK] button, and the user will be deleted from the user list.

### 4.2.8 Print settings

The analyzer provides a printing interface. Users can configure the printing mode of the specimen report, select the printer, and set the printing order of the assays.

#### Printer name

The printer's name drop-down list provides the names of all printers currently connected. The selected printer will be used for printing.

#### Printing mode

The printing modes include [Manual], [Released] and [Automatic]. [Manual] prints the report only after the user taps the [Print] button; [Released] prints automatically after all tests of the sample have been released; [Automatic] prints automatically after all tests of the sample have been completed.

#### Name

Facility name that displays in the report.

#### Address

The facility address that displays in the report.

#### Mailbox

The facility mailbox that displays in the report.

#### Phone

The facility phone that displays in the report.

## Assay Print Order

The user can set whether assays are printed in the specimen report and the display order. The [Assay Print Order] list includes current assays and calculated assays.

- 1- On the main menu, tap [Settings].
- 2- On the submenu, tap [System].
- 3- From the [System Settings] list, select [Print].
- 4- In the [Assay Print Order] list, select the assay name:
  - Check the [Print] checkbox to include the assay in the report.
  - Uncheck the [Print] checkbox to exclude the assay from the report.
  - Tap [Move Up] or [Move Down] to adjust the printing order.
- 5- Below the print configuration on the right, tap the [Save] button to save the current assay print order.

## 4.3 Table configuration

The user can customize the display of all tables under the [Orders] and [Data] menus. The user can also configure the visibility and display order of each table column as needed.

- 1- On the main menu, tap [Settings].
- 2- On the submenu, tap [Table]. The [Table] list displays all customizable tables according to [Main Menu] - [Submenu] - [Table Name].
- 3- From the [Table] list, select the table to be customized.
- 4- From the table column list on the right, select the column to be changed:
  - Check [Display] to display the column.
  - Uncheck [Display] to hide the column.
  - Tap the [Move Up] or [Move Down] button to adjust the display order of the column in the table.
- 5- Below the table column list on the right, tap the [Save] button, and the table settings will take effect immediately.

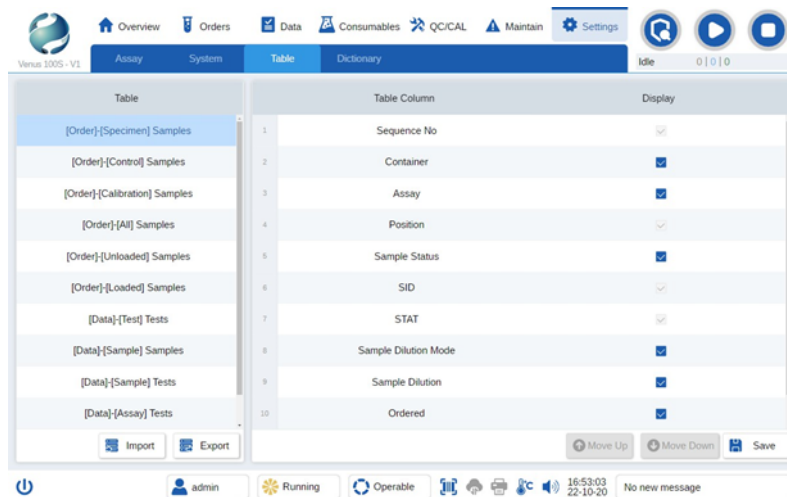

Figure: [Table] configuration

## 4.4 Dictionary configuration

The user can set the content of the drop-down menu for information fields such as result unit, sample comment, etc.

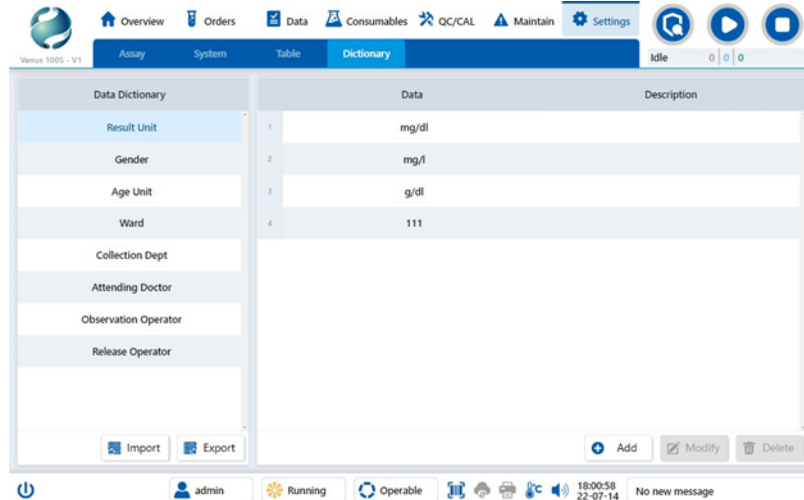

Figure: [Dictionary] configuration

#### 4.4.1 Add data

- 1- On the main menu, tap [Settings].
- 2- On the submenu, tap [Dictionary].
- 3- From the [Data Dictionary] list, select the field name of the data to be added.
- 4- Below the data list, tap the [Add] button to display the [Edit Data] window.
- 5- In the [Edit Data] window, enter [Data] and [Description].
- 6- Tap the [OK] button to save and close the [Edit Data] window. The new data can be viewed in the list.

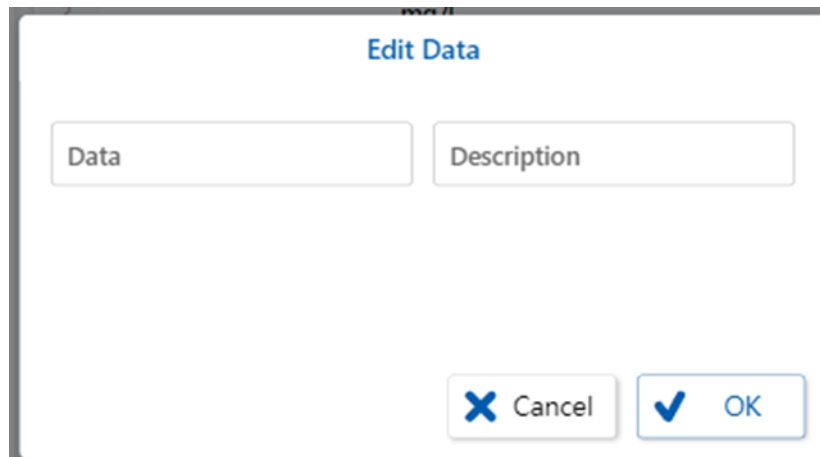

Figure: [Edit Data] window

#### 4.4.2 Modify data

- 1- On the main menu, tap [Settings].
- 2- On the submenu, tap [Dictionary].
- 3- From the [Data Dictionary] list, select the field name of the data to be modified.
- 4- Below the data list, tap the [Modify] button to display the [Edit Data] window.



- 5- In the [Edit Data] window, modify [Data] or [Description].
- 6- Tap the [OK] button to save and close the [Edit Data] window.

#### 4.4.3 Delete data

- 1- On the main menu, tap [Settings].
- 2- On the submenu, tap [Dictionary].
- 3- From the [Data Dictionary] list, select the field name of the data to be deleted.
- 4- Below the data list, tap the [Delete] button to display the deletion confirmation window.
- 5- Tap the [OK] button to confirm the deletion.

## Chapter 5 - Operating instructions

### 5.1 Daily operation procedure

Operation procedures for daily testing is usually done by the following steps:

Step No.	Step Name	Description
1	Analyzer power, user login, and analyzer initialization	-Cycle power to the analyzer -User login -Analyzer initialization
2	Preparation before performing sample processing	-Check reagent status -Check supply status -Load reagents -Load substrates -Load diluent -Load cleaning solution -Load enhanced cleaning solution -Load RVs -Empty the RV waste container -Empty the liquid waste container
3	Order creation	-Order sample tests (e.g., specimens, controls, calibrations, etc.)
4	Analyzer control	-Start sampling -Pause sampling -Stop the analyzer
5	Analyzer status monitoring	-Monitor the status of the reagent carousel -Monitor the status of the specimen carousel -Monitor the status of the supplies -Monitor the status of test results
6	Result handling	-View test results -Order a rerun -Release test results -Transmit test results

7	Daily maintenance	-Perform maintenance operations -Verify maintenance procedures
8	Analyzer shutdown and restart	-Shut down or restart

## 5.2 Analyzer power, user login, and analyzer initialization

### 5.2.1 Cycle power to the analyzer

- 1- Make sure the power connection cable is connected firmly.
- 2- Turn on the main power switch.
- 3- Press the computer power switch button to power on the UI computer.
- 4- The software will start automatically after the computer boots.

### 5.2.2 User login

The user can log in to the user interface computer using the default admin username and password provided.

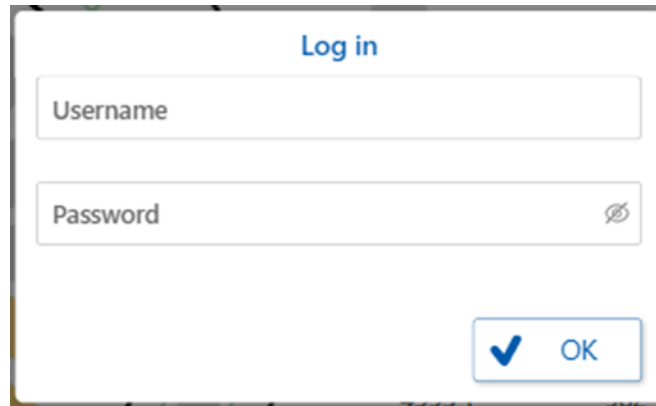

Figure: [Log in] window

#### First login after boots up

- 1- In the [Log in] window, enter the username and password.
- 2- Tap the [OK] button.

#### Switch current user

- 1- Tap the username button at the bottom of the software's main screen.
- 2- In the flyout, tap [Log out] to display the [Log in] window.
- 3- In the [Log in] window, enter the username and password.
- 4- Tap the [OK] button.

### 5.2.3 Analyzer initialization

Analyzer initialization refers to resetting the moving parts of the analyzer and restoring the data information. When the analyzer is in [Offline] or [Stopped] state, tap the [Initialize] button to start the initialization. After the initialization process is completed, the user will be prompted to empty the RV waste container the liquid waste container before using the analyzer for assay tests.

## 5.3 Preparation before performing sample processing

### 5.3.1 Check supply status

After the initialization of the analyzer is completed, the user can view the detailed information of each supply. Users can load, unload, replace or replenish them accordingly. Please refer to "Supply inventory management" for the specific operation of supplies management.

### 5.3.2 Check reagent status

After the initialization of the analyzer is completed, the user can view the detailed information of each reagent. Users can load, unload or replace reagents accordingly. For reagent management, please refer to "Reagent inventory management".

### 5.3.3 Check the analyzer maintenance status

Before running any test, the user should ensure that the analyzer is in a fault-free state. Select [Maintain] - [Notification] menu to view all current notification messages.

### 5.3.4 Check LIS connection status

If test information needs to be downloaded or uploaded using the LIS service, the user should ensure that the LIS connection stays connected.

- The [LIS Status] icon button at the bottom bar being gray indicates that the LIS function is disabled.
- The [LIS Status] icon button at the bottom bar being blue indicates that the LIS connection is connected.
- The [LIS Status] icon button at the bottom bar being yellow indicates that the LIS connection is disconnected.

Please refer to "LIS settings" for troubleshooting and configuration.

### 5.3.5 Check printer status

The printer needs to be properly connected to function.

The [Connection Status] icon button at the bottom bar being gray indicates that the printer is disconnected.

The [Connection Status] icon button at the bottom bar being blue indicates that the printer is connected.

The [Connection Status] icon button at the bottom bar being yellow indicates that the printer is currently under error status.

Please refer to "Printer Settings" for troubleshooting and configuration.

## 5.4 Order creation

The user can create and view specimen, control, and calibration orders under the [Orders] menu. Please refer to the corresponding chapter and section for the order procedures and related settings.

Sample type	Reference chapter and section
Calibrator	Calibration procedures
Control	Quality control procedures
Specimen	Specimen order procedures

## 5.5 Analyzer control

### 5.5.1 Start

When the analyzer is in the [Idle] or [Stopped] state, tap the [Start/Pause] icon button to start the sampling module and analyzing module.

### 5.5.2 Pause

When the analyzer is in the state of [Processing], tap the [Start/Pause] icon button to pause the sampling process. Tap the [Start/Pause] icon button again to resume sampling. The pause operation will only affect the sampling module. The sampled tests will continue with the procedure without interruption.

### 5.5.3 Stop

In case of unexpected situations, the user can stop the analyzer from further mechanical movements by tapping the [Stop] icon button on the analyzer computer user interface. Under the [Stopped] state, all commands from the analyzer to the controller will be suspended, which may significantly affect the test results. Tapping the [Stop] icon button may not immediately stop the mechanical movements. To avoid mechanical damage or personal injury caused by moving mechanical movements, please use the red mechanical emergency stop button on the side of the analyzer.

## 5.6 Analyzer status monitoring

At any time after the completion of initialization, users can tap the [Overview] main menu to navigate to the analyzer status overview screen where the following status can be monitored.

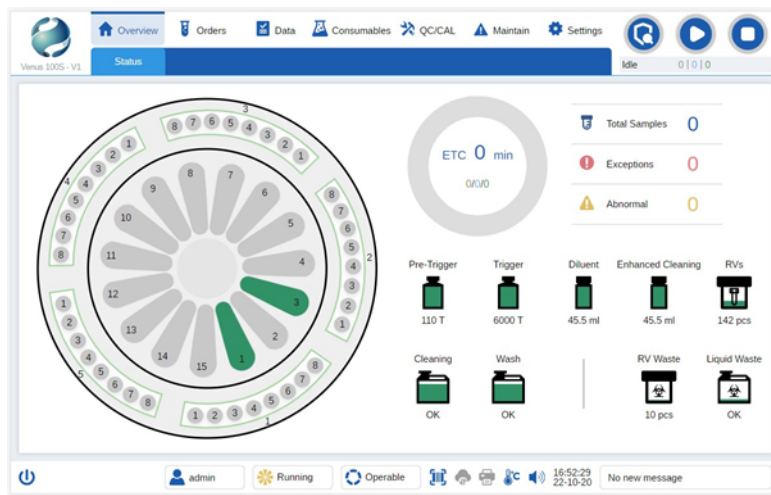





Figure: [Status] screen

### 5.6.1 Reagent status







The reagent icons and their corresponding status on the reagent carousel are shown below. Tapping on a reagent position will navigate to the [Consumables]-[Reagents] screen, and the information row of this reagent will be highlighted.

Icon	Status	Description
	Empty	No reagent is installed at this position.
	Disabled	This position has a reagent installed but the reagent is disabled. Tests designated to this reagent will not be processed. This reagent will be unavailable for selection in the QC, calibration, or standardization order screen.
	OK	This position has a reagent installed, and the reagent is in OK condition.

	Info	This position has a reagent installed, and an information message is generated for this reagent. (e.g., the remaining test count below ordered count)
	Alert	This position has a reagent installed, and an alert message is generated for this reagent. (e.g., no QC)
	Critical	This position has a reagent installed, and a critical message is generated for this reagent. (e.g., no master curve.)





### 5.6.2 Sample status

The sample icons and their corresponding status on the sample carousel are shown below. Tapping on a sample position will navigate to the [Orders]-[Loaded] screen and the information row of this sample will be highlighted.

Icon	Status	Description
	Empty	No sample placed at this position.
	NTA or pending	Sample has no test available or no test has been processed yet.
	Processing or paused	Sample has been partially processed.
	Analyzing	Sample has finished processing for all tests but results are not reported yet. This sample can be removed or replaced.
	Completed	Results are reported for all tests and all are within the normal reference range. No exception occurred during the process. This sample can be removed or replaced.
	Abnormal	At least one result of the sample falls outside of the normal reference range.
	Exception	Exception occurred when processing the sample, or a test result of the sample is flagged with an exception. The user is required to confirm the notification message or result flag and rerun part of the tests or all the tests if necessary.

### 5.6.3 Supply status

The supply colors and their corresponding status are shown below. Tapping on a supply icon will navigate to the [Consumables]-[Supplies] screen and the information row of this supply will be highlighted.

Color	Status	Description
	Off-loaded	Supply is not installed or unloaded.
	OK	Supply is in OK condition.
	Info	An information message is generated for the supply. (e.g., the remaining test count below ordered count)
	Alert	An alert message is generated for the supply. (e.g., the remaining test count below notification value)
	Critical	A critical message is generated for the supply. (e.g., the remaining test count is 0.)

### 5.6.4 Test data status

The test data status area displays data related to today's tests.

Data Name	Data Description
ETC XXmin	The estimated time for all ordered tests loaded in the sample carousel to be completed.
Test progress	The numbers displayed in order from left to right represent the following data: Number of pending tests Number of running tests Number of completed tests
Total samples	Total number of samples ordered.
Exceptions	Total number of tests with exceptions.

Abnormal	Total number of tests with results falling outside the normal reference range.
----------	--

### 5.7 Results handling

After tests are completed, the user can tap on the [Data] menu to view [Test], [Sample], [Assay], [Exception], and the [Statistics] screen. On these screens, the user can release, transmit or print the test results. Please refer to the "Data handling" for more details.

### 5.8 Analyzer shutdown and restart

After the analyzer finished daily tests or in some scenarios where the analyzer needs to be shut down or restarted, the user can tap the [Power] icon button and select [Shutdown] or [Restart]. If there were tests done before the shutdown or the restarting, the analyzer will perform an automatic database backup.

## Chapter 6 - Reagent and supply management

### 6.1 Reagent inventory management

#### 6.1.1 Check reagent status

Reagent list on the [Reagents] screen under the [Consumables] main menu displays detailed information of the reagent loaded at each position, including [Name], [Lot], [Remaining], [Stability], [EXP Date], [Status] and [SN]. The background color of the reagent row will change to one of the four colors (gray, red, yellow, or blue) when the reagent status is not OK. If multiple conditions are present, the colors are decided in the following order:

Priority	Color	Reagent status
1	Gray	The reagent is disabled.
2	Red	A critical notification condition is present.
3	Yellow	An alert notification condition is present.
4	Blue	An information notification condition is present.

**NOTE:** When multiple bottles of the same reagent are loaded, the spare bottles will be marked with "\*".

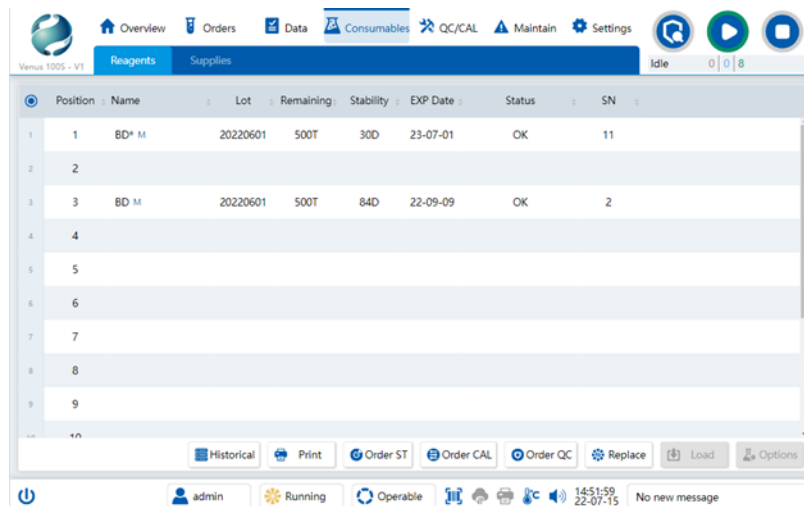

Figure: [Reagents] screen

#### 6.1.2 Load reagents

After the initialization process of the analyzer is completed, the user is allowed to load the corresponding reagents of the corresponding assays. The reagent can be loaded automatically or manually. The automatic reagent loading option is available when the analyzer has the barcode reader and a barcode is attached to the reagent bottle. The reagent carousel is required to be in the [Operable] state before loading reagents.

### Automatic reagent loading

- 1- On the bottom bar, tap the [Reagent Carousel] icon button.
- 2- In the flyout, tap the [Replace] button.
- 3- Wait until the reagent carousel status changes to [Operable].
- 4- In the flyout, tap the target reagent carousel position button for the reagent to be loaded.
- 5- Wait until the reagent carousel rotates to the selected position and the indicator light of the reagent carousel control button changes from yellow to white.
- 6- Open the reagent compartment lid.
- 7- Place the reagent into the selected carousel position.
- 8- Close the reagent compartment lid.
- 9- Repeat steps 4 - 8 until all reagents have been loaded into the reagent carousel.
- 10- In the flyout, tap the [Finish] button to complete the reagent replacement.

### Manual reagent loading

- 1- On the main menu, tap [Consumables].
- 2- On the submenu, tap [Reagents].
- 3- Under the reagent list, tap the [Replace] button.
- 4- Wait until the reagent carousel status changes to [Operable].
- 5- From the reagent list, select the row of the position where the reagent needs to be loaded.
- 6- Under the reagent list, tap the [Load] button to display the [Load Reagent] window.
- 7- Wait until the reagent carousel rotates to the selected carousel position and the indicator light of the reagent carousel control button changes from yellow to white.
- 8- Open the reagent compartment lid.
- 9- In the [Load Reagent] window, select an [Input] option.
  - If the [Input] option selected is [Barcode], enter the reagent barcode in the [Barcode] text box.
  - If the [Input] option selected is [Detail], fill in the reagent information in the form.
- 10- Place the reagent into the selected carousel position.
- 11- In the [Load Reagent] window, tap the [OK] button.
  - The information of the reagent will appear in the reagent list and be marked with **M**, indicating that this reagent is loaded manually.
- 12- Close the reagent compartment lid.
- 13- Repeat steps 5 - 12 until all reagents have been loaded into the reagent carousel.
- 14- Under the reagent list, tap the [Finish] button to complete the reagent replacement.

Figure: [Load Reagent] window

### 6.1.3 Unload reagents

After the initialization process of the analyzer is completed, the user is allowed to unload the onboard reagents. The reagent carousel is required to be in the [Operable] state before unloading reagents. For reagents that are automatically loaded, the user can take out the reagent, and the analyzer can identify this information after the next reagent scanning. For reagents that are manually loaded, the user needs to tap the [Unload] button on the [Reagents] screen under the [Consumables] main menu to notify the analyzer that reagents have been unloaded.

#### Automatic reagent unloading

- 1- On the bottom bar, tap the [Reagent Carousel] icon button.
- 2- In the flyout, tap the [Replace] button.
- 3- Wait until the reagent carousel status to change to [Operable].
- 4- In the flyout, tap the target reagent carousel position button for the reagent to be unloaded.
- 5- Wait until the reagent carousel rotates to the selected position and the indicator light of the reagent carousel control button changes from yellow to white.
- 6- Open the reagent compartment lid.
- 7- Remove the reagent from the selected carousel position.
- 8- Close the reagent compartment lid.
- 9- Repeat steps 4 - 8 until all reagents have been unloaded from the reagent carousel.
- 10- In the flyout, tap the [Finish] button to complete the reagent replacement.

#### Manual reagent unloading

- 1- On the main menu, tap [Consumables].
- 2- On the submenu, tap [Reagents].
- 3- Under the reagent list, tap the [Replace] button.



- 4- Wait until the reagent carousel status changes to [Operable].
- 5- From the reagent list, select the row of the reagent that needs to be unloaded.
- 6- Under the reagent list, tap the [Unload] button.
- 7- When a confirmation message is displayed, tap [OK].
- 8- Wait until the reagent carousel rotates to the selected position and the indicator light of the reagent carousel control button changes from yellow to white.
- 9- Open the reagent compartment lid.
- 10- Remove reagent from selected carousel position.
- 11- Close the reagent compartment lid.
- 12- Repeat steps 5 - 11 until all reagents have been unloaded from the reagent carousel.
- 13- Under the reagent list, tap the [Finish] button to complete the reagent replacement.

#### 6.1.4 Disable reagents

The user can disable reagents on demand. When a reagent is disabled, it will not be used for assay test or be used for the reagent remaining test count calculation. Disabled reagents are indicated by gray background in the reagent list position rows on the [Reagents] screen under the [Consumables] main menu and also in the reagent carousel on the [Overview] page.

#### Disable reagents

The user can disable reagents when the analyzer is in [Idle] state.

- 1- On the main menu, tap [Consumables].
- 2- On the submenu, tap [Reagents].
- 3- From the reagent list, select the row of the reagent that needs to be disabled.
- 4- Under the reagent list, tap the [Options] button to display the [Reagent Options] window.
- 5- In the [Reagent Options] window, check the [Disable reagent] checkbox.
- 6- In the [Reagent Options] window, tap the [OK] button. After the [Reagent Options] window is closed, the disabled reagent row will be displayed in the reagent list with gray background.

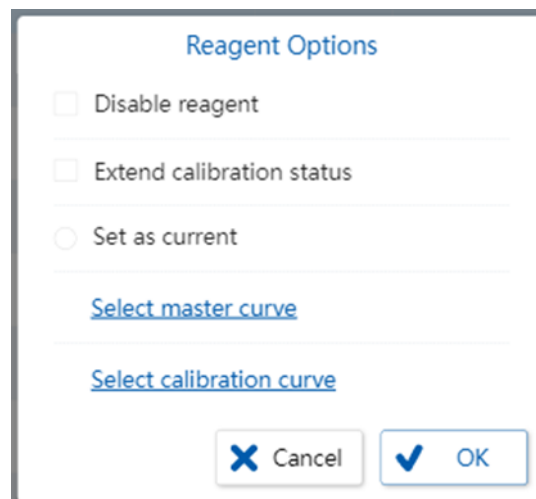

Figure: [Reagent Options] window

#### Re-enable reagents

The user can re-enable a reagent when the analyzer is in any state.

- 1- On the main menu, tap [Consumables].
- 2- On the submenu, tap [Reagents].
- 3- From the reagent list, select the row of the reagent that needs to be re-enabled.
- 4- Under the reagent list, tap the [Options] button to display the [Reagent Options] window.
- 5- In the [Reagent Options] window, uncheck the [Disable Reagent] checkbox.
- 6- In the [Reagent Options] window, tap the [OK] button. After the [Reagent Options] window is closed, the re-enabled reagent will restore its background color in the reagent list based on its current reagent status.

### **6.1.5 Set reagents as current bottles**

When multiple bottles of the same reagent are loaded, the analyzer will set the reagent that has the earliest open-bottle date as the default current bottle. The current bottle will be used to process a test if no specific reagent is designated for it. The spare bottles are marked with a "\*" mark. The user can set a reagent as the current bottle by selecting the [Set as current] option.

- 1- On the main menu, tap [Consumables].
- 2- On the submenu, tap [Reagents].
- 3- From the reagent list, select the reagent row that needs to be set as the current bottle.
- 4- Under the reagent list, tap the [Options] button to display the [Reagent Options] window.
- 5- In the [Reagent Options] window, check the [Set as current] radio button.
- 6- In the [Reagent Options] window, tap the [OK] button. After the [Reagent Options] window is closed, the reagent which is set as the current bottle will not be marked with "\*" in the reagent list.

### **6.1.6 Extend validity of calibration parameters**

When the calibration parameters exceed the calibration interval, the calibration status changes to [Calibration Expired]. The reagents with expired calibration status will not be available for testing. If the user verifies that the calibration parameters are still valid, the user can extend the usage of the current calibration parameters by using the [Extend calibration status] function. Only reagents with a calibration status of [Calibration Expired] or [Calibration OK] are allowed to use this function. Test results calculated using the extended calibration parameters will be associated with a flag.

#### **Enable calibration extension**

- 1- On the main menu, tap [Consumables].
- 2- On the submenu, tap [Reagents].
- 3- From the reagent list, select the reagent row of which the calibration parameter needs to be extended.
- 4- Under the reagent list, tap the [Options] button to display the [Reagent Options] window.
- 5- In the [Reagent Options] window, check the [Extend calibration status] checkbox.
- 6- In the [Reagent Options] window, tap the [OK] button. After the [Reagent Options] window is closed, the reagent will display the [Calibration Extended] status under the [Status] column.

#### **Disable calibration extension**

The reagent whose [Status] is shown as [Calibration Extended] can be automatically updated when new calibration tests are performed. The user can also manually cancel the calibration extension by the following steps.

- 1- On the main menu, tap [Consumables].
- 2- On the submenu, tap [Reagents].
- 3- From the reagent list, select the reagent row of which the calibration extension needs to be canceled.
- 4- Under the reagent list, tap the [Options] button to display the [Reagent Options] window.
- 5- In the [Reagent Options] window, uncheck the [Extend calibration status] checkbox.
- 6- In the [Reagent Options] window, tap the [OK] button. After the [Reagent Options] window is closed, the reagent will display the current calibration status under the [Status] column.

### 6.1.7 Select calibration curve

When multiple calibration curves are available for the reagent, the user can select a desired calibration curve by the following steps or refer to View and apply the calibration curve.

- 1- On the main menu, tap [Consumables].
- 2- On the submenu, tap [Reagents].
- 3- From the reagent list, select the reagent row of which the calibration curve needs to be re-selected.
- 4- Under the reagent list, tap the [Options] button to display the [Reagent Options] window.
- 5- In the [Reagent Options] window, tap the [Select calibration curve] navigation link to navigate to the [Curves] screen under the [QC/CAL] main menu.
- 6- In the [Calibration Curves] list, select different calibration curves from the [Calibration] list to view the calibration details.
- 7- In the [Calibration Curves] list, check the radio button in front of the desired calibration curve.
- 8- When a confirmation message is displayed, tap [OK].

### 6.1.8 Historical reagents

The [Historical Reagents] window displays the reagent information for reagents that are currently loaded on the analyzer, or for reagents that were previously loaded on the analyzer and removed. The user can access the [Historical Reagents] window by the following steps.

- 1- On the main menu, tap [Consumables].
- 2- On the submenu, tap [Reagents].
- 3- Under the reagent list, tap the [Historical] button to display the [Historical Reagents] window. Historical reagents will be displayed based on the time range preset in [Default time range for display of historical reagents] by default.
- 4- In the [Historical Reagents] window, tap the [Search] button to display the search conditions flyout.
- 5- In the search conditions flyout, fill in more specific conditions to search for.
- 6- In the search conditions flyout, tap the [OK] button. All eligible reagents will be displayed in the historical reagent list.

Historical Reagents						
	Name	Lot	SN	MFG Date	EXP Date	Opened Date
1	BD	20220601	11	22-07-01	23-07-01	22-07-15
2	BD	220715	11	22-07-01	23-07-01	22-07-15

Figure: [Historical Reagents] window

### 6.1.9 Print reagent list

The user can print out information about the currently loaded reagents by the following steps.

- 1- On the main menu, tap [Consumables].
- 2- On the submenu, tap [Reagents].
- 3- Under the reagent list, tap the [Print] button to display the [Print Reagents] window. If no reagent information row is selected, all reagent rows will be printed. Otherwise, only selected reagent information rows will be printed.
- 4- In the [Print Reagents] window, tap the [Print] button to start printing.

### 6.2 Supply inventory management

Name	Quantity	Unit	Stability	EXP Date	Lot	SN
1 Pre-Trigger	3996	T	23D	23-10-15	221014	001
2 Trigger	1857	T	23D	23-10-15	221014	001
3 Diluent M	222.799	ml	23D	23-10-15	221014	001
4 Enhanced Cleaning Solution M	222.799	ml	23D	23-10-15	221014	001
5 Cleaning Solution	OK					
6 Wash	OK					
7 RVS	416	pcs				
8 RV Waste	0	pcs				
9 Liquid Waste	OK					

Figure: [Supplies] screen

#### 6.2.1 Check supply status

Supply list on the [Supplies] screen under the [Consumables] main menu displays detailed information of each supply, including [Name], [Quantity], [Unit], [Stability], [EXP date], [Lot], and [SN]. The background color of the supply row will change to one of the four colors (gray, red, yellow, or blue) when the supply status is not OK. If multiple conditions are present, the colors are decided in the following order:

Priority	Color	Supply status
1	Gray	The supply is not installed.
2	Red	A critical notification condition is present.
3	Yellow	An alert notification condition is present.
4	Blue	An information notification condition is present.

### Load substrates

Up to two different substrates can be loaded on this analyzer. The user needs to enter the substrate information during the substrate loading process. Information such as quantity and stability are automatically calculated and refreshed after each use. When the analyzer is in the [Idle] or [Paused] state and the running test number is 0, the substrate information can be entered by the following methods.

#### Read substrate information with a barcode reader

The substrate information can be acquired with a barcode reader. The substrate information will be displayed in the [Load Substrate] window if barcode information is parsed successfully.

- 1- On the main menu, tap [Consumables].
- 2- On the submenu, tap [Supplies].
- 3- From the supply list, select the corresponding substrate information row.
- 4- Under the supply list, tap the [Load] button to display the [Load (Substrate Name)] window. If the substrate information row is not empty, tap the [Unload] button to manually unload the last used substrate before tapping the [Load] button.
- 5- After the [Load (Substrate Name)] window displays, scan the substrate barcode with the hand-held barcode reader, and the analyzer will try to parse the substrate information from the barcode.
- 6- In the [Load (Substrate Name)] window, verify the substrate information such as [Net Quantity], [Lot], [SN], [MFG Date], [Shelf Life], and [EXP Date].
- 7- In the [Load (Substrate Name)] window, tap the [OK] button. The substrate information will appear in the supply list.

#### Enter substrate information manually

- 1- On the main menu, tap [Consumables].
- 2- On the submenu, tap [Supplies].
- 3- From the supply list, select the corresponding substrate information row.
- 4- Under the supply list, tap the [Load] button to display the [Load (Substrate Name)] window. If the substrate information row is not empty, tap the [Unload] button to manually unload the last used substrate before tapping the [Load] button.
- 5- In the [Load (Substrate Name)] window, enter [Net Quantity], [Lot], [SN], [MFG Date], [Shelf Life], and [EXP Date] of the substrate.
- 6- In the [Load (Substrate Name)] window, tap the [OK] button. The substrate information will appear in the supply list.

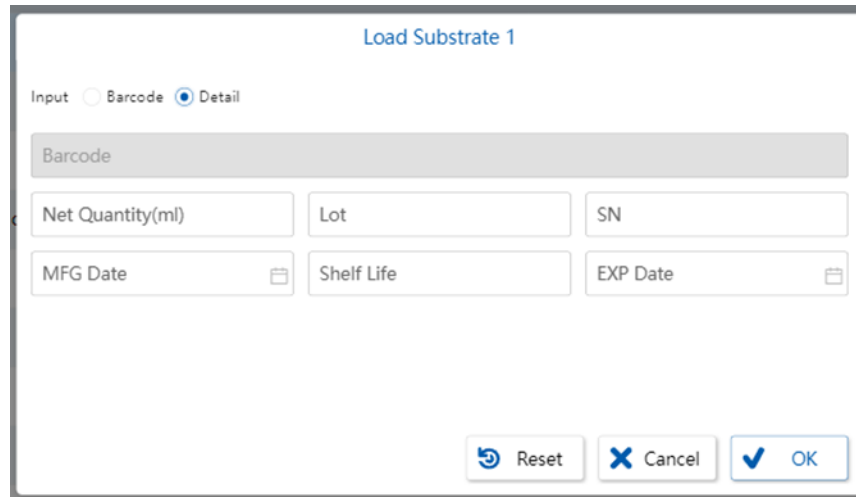

Figure: [Load (Substrate Name)] window

### 6.2.2 Load diluent on the sample carousel

The analyzer can perform automated dilution by aspirating the diluent loaded on the sample carousel. The diluent on the sample carousel can be replaced or removed when the sample carousel is in [Operable] state.

#### Automatic diluent loading

The built-in barcode reader can acquire the diluent information automatically when a barcode is attached to the diluent bottle.

- 1- On the bottom bar, tap the [Sample Carousel] icon button.
- 2- In the flyout, tap the [Bottle 1] or [Bottle 2] button.
- 3- Wait until the sample carousel status to change to [Operable] and the indicator light of the sample carousel control button changes from yellow to white.
- 4- Open the sample compartment lid.
- 5- Place the diluent at the bottle position.
- 6- Close the sample compartment lid.
- 7- In the flyout, tap the [Read Bottle] button, and the barcode and its remaining quantity of the diluent bottle will be read automatically. If the barcode is parsed successfully, the user can navigate to the [Supplies] screen under [Consumables] main menu to view the details of the diluent.

#### Manual diluent loading

The manual information entering is also available in case of an unexpected situation.

- 1- On the main menu, tap [Consumables].
- 2- On the submenu, tap [Supplies].
- 3- From the supply list, select the [Bottle 1] or [Bottle 2] row.
- 4- Under the supply list, tap the [Load] button to display the [Load Bottle] window. If the bottle information row is not empty, tap the [Unload] button to manually unload the previous bottle before tapping the [Load] button.
- 5- Wait until the sample carousel status to change to [Operable] and the indicator light of the sample carousel control button changes from yellow to white.

- 6- Open the sample compartment lid.
- 7- In the [Load Bottle] window, select an [Input] option.
  - If the [Input] option selected is [Barcode], enter the diluent barcode in the [Barcode] text box.
  - If the [Input] option selected is [Detail], select [Diluent] from the [Category] drop-down list and fill in the detailed information of the diluent.
- 8- Place the diluent at the bottle position.
- 9- Close the sample compartment lid.
- 10- In the [Load Bottle] window, tap the [OK] button.

The diluent will appear in the supply list and be marked with **M**, indicating that the details of the diluent are entered manually.

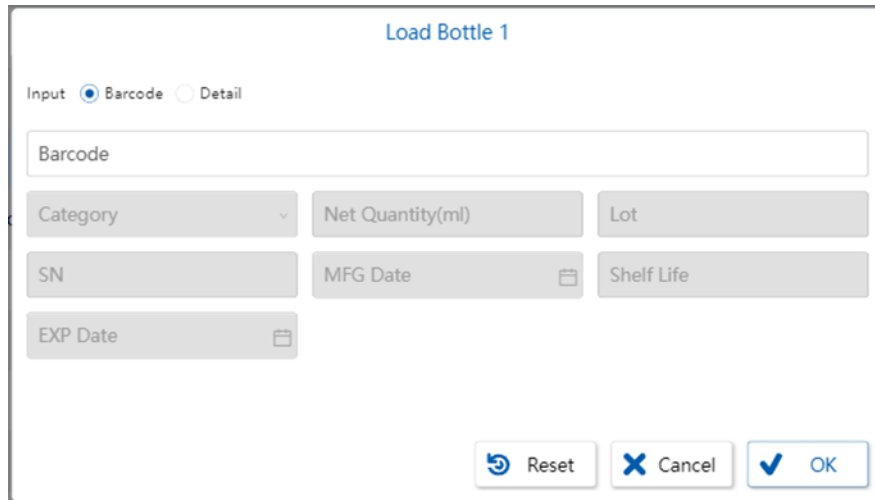

Figure: [Load Bottle] window

### 6.2.3 Load enhanced cleaning solution to sample carousel

The analyzer performs an enhanced cleaning for the pipettor automatically by aspirating and dispensing the enhanced cleaning solution loaded on the sample carousel. The enhanced cleaning solution can be replaced or removed when the sample carousel is in [Operable] state.

#### Automatic enhanced cleaning solution loading

The built-in barcode reader can acquire the enhanced cleaning solution information automatically when a barcode is attached to the enhanced cleaning solution bottle.

- 1- On the bottom bar, tap the [Sample Carousel] icon button.
- 2- In the flyout, tap the [Bottle 1] or [Bottle 2] button.
- 3- Wait until the sample carousel status to change to [Operable] and the indicator light of the sample carousel control button changes from yellow to white.
- 4- Open the sample compartment lid.
- 5- Place the enhanced cleaning solution at the bottle position.
- 6- Close the sample compartment lid.
- 7- In the flyout, tap the [Read Bottle] button, and the barcode and its remaining quantity of the enhanced cleaning solution bottle will be read automatically. If the barcode is parsed successfully, the user can

navigate to the [Supplies] screen under [Consumables] main menu to view the details of the enhanced cleaning solution.

### Manual enhanced cleaning solution loading

The manual information entering is also available in case of an unexpected situation.

- 1- On the main menu, tap [Consumables].
- 2- On the submenu, tap [Supplies].
- 3- From the supply list, select the [Bottle 1] or [Bottle 2] row.
- 4- Under the supply list, tap the [Load] button to display the [Load Bottle] window. If the bottle information row is not empty, tap the [Unload] button to manually unload the previous bottle before tapping the [Load] button.
- 5- Wait until the sample carousel status to change to [Operable] and the indicator light of the sample carousel control button changes from yellow to white.
- 6- Open the sample compartment lid.
- 7- In the [Load Bottle] window, select an [Input] option.
  - If the [Input] option selected is [Barcode], enter the enhanced cleaning solution barcode in the [Barcode] text box.
  - If the [Input] option selected is [Detail], select [Enhanced Cleaning Solution] from the [Category] drop-down list and fill in the detailed information of the enhanced cleaning solution.
- 8- Place the enhanced cleaning solution at the bottle position.
- 9- Close the sample compartment lid.
- 10- In the [Load Bottle] window, tap the [OK] button. The enhanced cleaning solution will appear in the supply list and be marked with **M**, indicating that the details of the enhanced cleaning solution are entered manually.

### 6.2.4 Replenish cleaning solution

The analyzer will use cleaning solution to clean the pipettor after each dispensing when running different tests of the same sample. The installed cleaning solution can be replenished when the analyzer is in the [Offline] state and [Idle] state, or in the [Paused] state while number of running tests is 0.

### 6.2.5 Replenish wash buffer

Wash buffer is used in the wash step to help remove the unbound material. The wash buffer can be replenished when the analyzer is in the [Offline] state and [Idle] state, or in the [Paused] state while number of running tests is 0.

### CAUTION

- Wash buffer, substrate (trigger or pre-trigger), and the enhanced cleaning solution used should be provided by the manufacturer.
- The cleaning solution is usually purified water (depending on the assay). The purified water should be classified as Type II grade.

### 6.2.6 Load RVs



The analyzer uses disposable RVs as containers for sample and reagent reactions. The user can replenish the RVs by pouring them into the RV hopper. The RVs are automatically disposed into the RV waste container after tests. The RVs can be replenished when the analyzer is in any state.

- 1- Open the RV hopper cover.
- 2- Pour the clean RVs into the RV hopper.
- 3- Close the RV hopper cover.
- 4- On the main menu, tap [Consumables].
- 5- On the submenu, tap [Supplies].
- 6- From the supply list, select the [RVs] row.
- 7- Under the supply list, tap the [Add] button to display the [Load RVs] window.
- 8- In the [Load RVs] window, enter the estimated quantity of RVs added in the [Quantity] text box.
- 9- In the [Load RVs] window, tap the [OK] button. The quantity of [RVs] in the supply list is displayed as the sum of the last remaining quantity and the number of RV entered in the previous step.

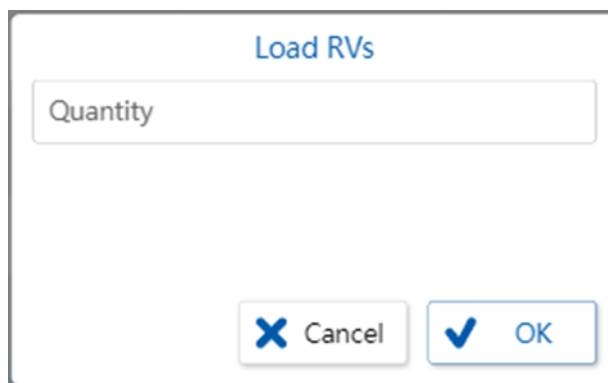

Figure: [Load RVs] window

#### CAUTION

RVs are supplied by Carbon Technologies LLC

#### 6.2.7 Empty the RV waste container

After the tests are completed, the analyzer will automatically discard the used RVs into the RV waste container. The user should empty the RV waste container before and after the daily testing or when the RV waste container quantity is [Excess].

- 1- On the main menu, tap [Consumables].
- 2- On the submenu, tap [Supplies].
- 3- From the supply list, select the [RV Waste] row.
- 4- Under the supply list, tap the [Unload] button.
- 5- When a confirmation message is displayed, tap [OK].
- 6- Pull out the RV waste container and empty the RV waste container according to the laboratory biohazard waste disposal procedures of the facility.
- 7- Put the RV waste container back to its position.
- 8- From the supply list, select the [RV Waste] row.
- 9- Under the supply list, tap the [Load] button.
- 10- When a confirmation message is displayed, tap the [OK] button.

11- After the [OK] button is tapped, the quantity of [RV Waste] in the supply list will be reset to 0.

### 6.2.8 Replace the liquid waste container

When the analyzer uses an external liquid waste container to collect liquid waste, the liquid waste container should be emptied before and after the daily testing or when the liquid waste container quantity is [Excess] to prevent the liquid waste from overflowing. When replacing the liquid waste container, remove the liquid waste tubing and quickly place it in an empty liquid waste container to prevent the liquid waste from dripping.

## Chapter 7 - Calibration procedures

Calibration is the process used to analyze calibrators of a known concentration, to record system response values, and to plot measured values against the known concentration. A calibration must be performed when a new reagent lot is used for sample processing. Otherwise, results cannot be calculated. A calibration may need to be performed when:

- The calibration is expired.
- A new reagent bottle of the same lot is loaded.
- A different bottle of calibrator is used.
- The pipettor probe or other parts is replaced.
- QC failed when the reagent, calibrator and the control are all within the stability date.

### 7.1 Input calibrator information

#### 7.1.1 Add bar-coded calibrator information

The information of the calibrator will appear in the [Calibrators] list on the [Calibrators] screen under the [QC/CAL] main menu with an [Opened Date] of the current time.

#### Scan the barcode with a barcode reader

- 1- Scan the barcode on the calibrator information card with a barcode reader. The software will try to parse the barcode. If the information is parsed successfully, the [Edit Calibrator] window will automatically display with the detailed calibrator information.
- 2- In the [Edit Calibrator] window:
  - Tap the [OK] button to save the calibrator information.
  - Tap the [Cancel] button to close the window without saving.

#### Input the barcode in the software user interface

- 1- On the bottom bar, tap the [Barcode] icon button.
- 2- In the flyout, input the barcode on the calibrator information card. The software will try to parse the barcode. If the information is parsed successfully, the [Edit Calibrator] window will automatically display with the detailed calibrator information.
- 3- In the [Edit Calibrator] window:
  - Tap the [OK] button to save the calibrator information.
  - Tap the [Cancel] button to close the window without saving.

### 7.1.2 Add calibrator information manually

The information of the calibrator will appear in the [Calibrators] list on the [Calibrators] screen under the [QC/CAL] main menu with an [Opened Date] of the current time. The calibrator will be marked with **M** after the name to indicate that the information was input manually.

- 1- On the main menu, tap [QC/CAL].
- 2- On the submenu, tap [Calibrators].
- 3- Under the [Calibrators] list, tap the [Add] button to display the [Edit Calibrator] window.
- 4- In the [Edit Calibrator] window, fill in the detailed information of the calibrator.
- 5- In the [Edit Calibrator] window:
  - Tap the [OK] button to save the calibrator information.
  - Tap the [Cancel] button to close the window without saving.
  - Tap the [Reset] button to clear the calibrator information.

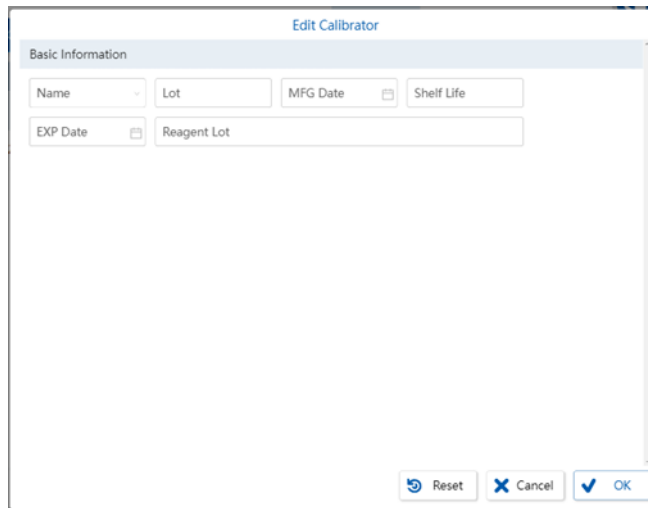

The screenshot shows the 'Edit Calibrator' window with a title bar 'Edit Calibrator'. Below the title bar is a section titled 'Basic Information'. This section contains several input fields: 'Name' (a dropdown menu), 'Lot', 'MFG Date' (a date picker), 'Shelf Life', 'EXP Date' (a date picker), and 'Reagent Lot' (a text input field). At the bottom of the window, there are three buttons: 'Reset' (with a circular arrow icon), 'Cancel' (with an 'X' icon), and 'OK' (with a checkmark icon).

Figure: [Edit Calibrator] window

### 7.1.3 View calibrator information

- 1- On the main menu, tap [QC/CAL].
- 2- On the submenu, tap [Calibrators].
- 3- From the [Calibrators] list, select a calibrator in the [Calibrators] list. The user can view the concentration value for each concentration level of the assay corresponding to the calibrator in the [Concentration Data] table on the right side of the screen. The [Calibrators] list displays the calibrators whose [Opened Date] are within the range set in [Default time range for display] of the [Calibrators] settings on the [System] screen under the [Settings] main menu by default.
- 4- Under the [Calibrators] list, tap the [Search] button to search for any previously saved calibrator according to the conditions filled in.
- 5- Under the [Calibrators] list, tap the [Print] button to print the selected calibrators in the [Calibrators] list. If no calibrator is selected, the whole list will be printed.

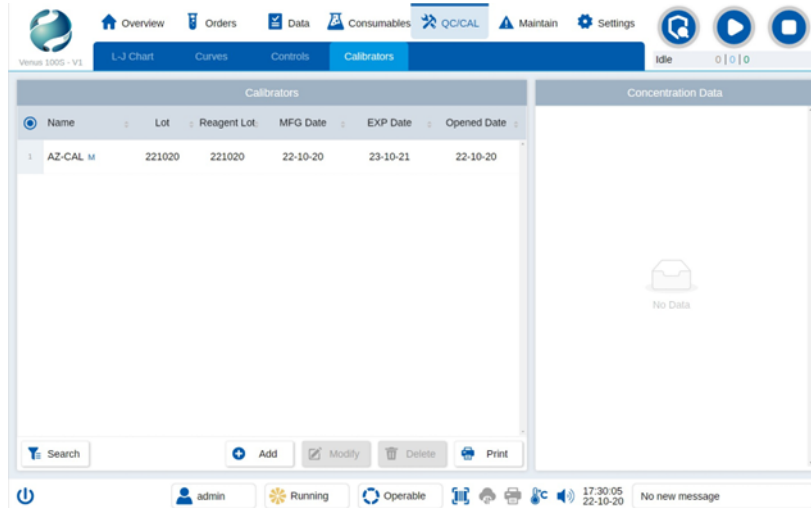

Figure: [Calibrators] screen

### 7.1.4 Modify calibrator information

Only calibrators that are manually added can be modified.

- 1- On the main menu, tap [QC/CAL].
- 2- On the submenu, tap [Calibrators].
- 3- From the [Calibrators] list, select a calibrator that was marked with **M**.
- 4- Under the [Calibrators] list, tap the [Modify] button to bring up the [Edit Calibrator] window.
- 5- In the [Edit Calibrator] window, modify the information of the calibrator.
- 6- In the [Edit Calibrator] window:
  - Tap the [OK] button to save the modification.
  - Tap the [Cancel] button to discard the modification.

### 7.1.5 Delete calibrator information

Deleted calibrators can no longer be used for ordering new calibration tests.

- 1- On the main menu, tap [QC/CAL].
- 2- On the submenu, tap [Calibrators].
- 3- From the [Calibrators] list, select the calibrator to be deleted.
- 4- Under the [Calibrators] list, tap the [Delete] button.
- 5- When a confirmation message is displayed:
  - Tap the [OK] button to proceed with the deletion.
  - Tap the [Cancel] button to cancel the deletion.

### 7.2 Create calibration orders

- 1- On the main menu, tap [Orders].
- 2- On the submenu, tap [Calibration].
- 3- Under the calibration order list, tap the [Add] button.

- 4- In the sample editing area, select the calibrator to be used from the [Reference Material] drop-down list. When there are other calibrators of the same lot number with different concentration levels, the analyzer will automatically select them in groups. The selection of a particular calibrator can be canceled individually by tapping the [X] icon after the name of the calibrator. When a calibrator is selected, the reagent button associated with the calibrator will be enabled, while the rest of the reagent buttons will be disabled.
- 5- In the sample editing area, select the rack number and position from the [Rack Position] drop-down list according to the position of the calibrator on the sample rack. [Rack Position] can be left blank when the calibrator is labeled with a barcode. If neither the calibrator nor the sample rack has a barcode, or the scanner is not functioning, then [Carousel Position] needs to be filled in:
  - In the sample editing area, select from the [Carousel Position] drop-down list where the calibrator is located on the carousel.
- 6- Among the reagent buttons, tap the target reagent button to add calibration tests.
- 7- Under the sample editing area, tap [Save] to submit the calibration order.

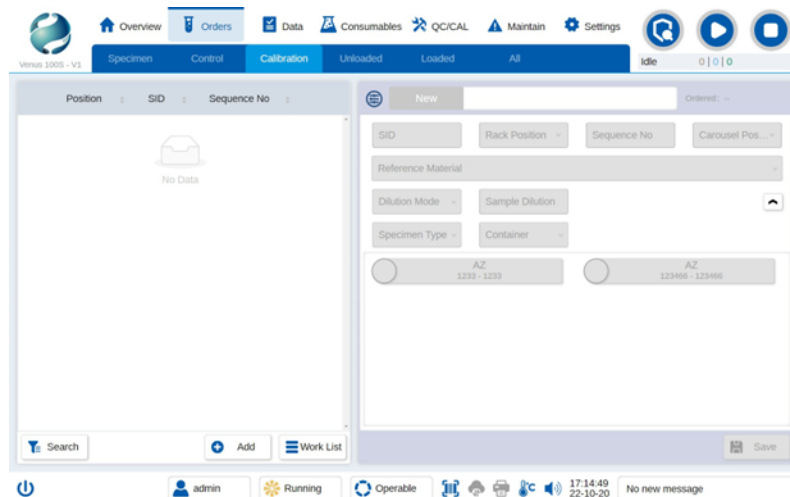

Figure: [Calibration] screen under [Orders] main menu

### 7.3 Shortcut to create calibration orders for onboard reagents

For the reagents installed on the analyzer, the analyzer software provides an easy way to order calibration tests. Unlike the regular way to order calibration tests on the [Calibration] screen under the [Orders] main menu, the shortcut to order calibration tests is on the [Reagents] screen under the [Consumables] main menu, allowing the user to order calibration tests with a clear view of the reagent status.

- 1- On the main menu, tap [Consumables].
- 2- On the submenu, tap [Reagents].
- 3- From the reagents list, select the reagents to be calibrated or proceed to the next step without selection.
- 4- Under the reagents list, tap the [Order CAL] button to bring up the [Order Calibration Tests] window. The [Order Calibration Tests] window lists the selected reagents. If no reagent is selected, all onboard reagents whose calibration status is not [OK] will be listed. The checkbox will be checked in front of the reagents that need to be calibrated. The user can change the calibration test details by expanding the reagents tree view and modifying the detail information. The user can tap [Expand All], [Collapse All], [Collapse unCALed] and [Expand unCALed] buttons to quickly expand and collapse the list.
- 5- In the [Order Calibration Tests] window:

- Tap the [OK] button to order all the checked calibration tests.
- Tap the [Cancel] button to discard the current operation.

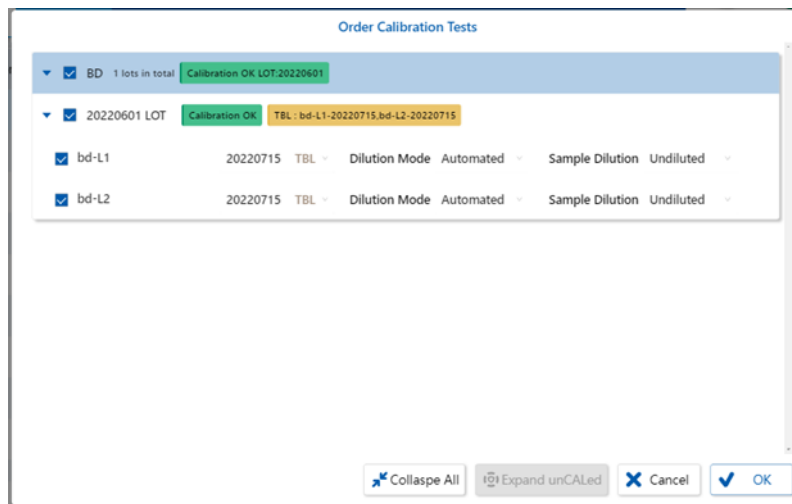

Figure: [Order Calibration Tests] window

## 7.4 Input master curve information

The master curve information of the reagent can be acquired automatically via the reagent information card on the reagent bottle when loaded on the reagent carousel, or by manually scanning the master curve information card with a barcode reader.

### 7.4.1 Manual master curve information card scanning

- 1- On the bottom bar, tap the [Barcode] icon button.
- 2- After the barcode flyout is displayed, scan the barcode on the master curve information card with the barcode reader. The analyzer will parse the master curve information and add it to the [Master Curves] list on the [Curve] screen under the [QC/CAL] main menu.

## 7.5 View master curve information

- 1- On the main menu, tap [QC/CAL].
- 2- On the submenu, tap [Curves].
- 3- At the bottom of the [Curves] screen, tap the [Search] button.
- 4- In the flyout:
  - Select the assay from the [Assay] drop-down list.
  - Select the date range from the [Date Range] date picker.
  - Tap the [OK] button. The master curve within this date range will be displayed in the [Reagent] list.
- 5- From the [Reagent] list, select a master curve. The curve information can be viewed in [Curve Parameters].

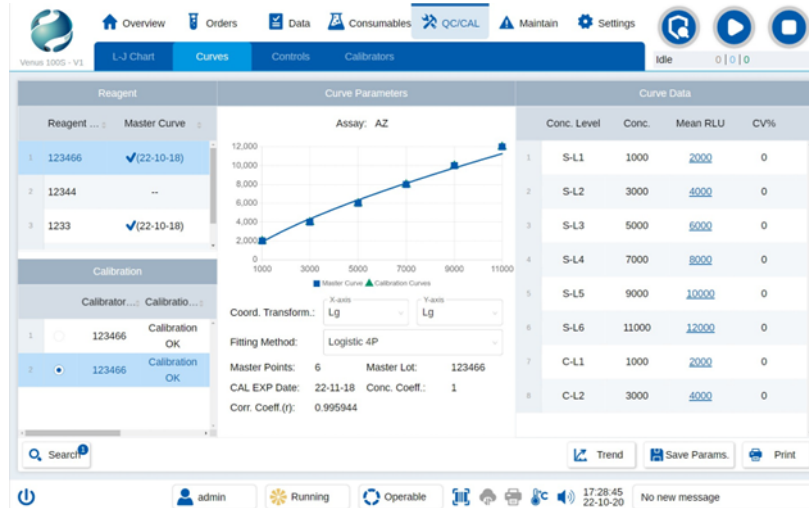

Figure: [Curves] screen

## 7.6 View and apply the calibration curve

### 7.6.1 View the calibration curve

- 1- On the main menu, tap [QC/CAL].
- 2- On the submenu, tap [Curves].
- 3- At the bottom of the [Curves] screen, tap the [Search] button.
- 4- In the flyout:
  - Select the assay from the [Assay] drop-down list.
  - Select the date range from the [Date Range] date picker.
  - Tap the [OK] button. The calibration curve within this date range will be displayed in the [Calibration] list.
- 5- From the [Calibration] list, select a calibration curve. The curve information can be viewed in [Curve Parameters] and [Curve Data].

### 7.6.2 Switch and apply the calibration curve

- 1- On the main menu, tap [QC/CAL].
- 2- On the submenu, tap [Curves].
- 3- At the bottom of the [Curves] screen, tap the [Search] button.
- 4- In the flyout:
  - Select the assay from the [Assay] drop-down list.
  - Select the date range from the [Date Range] date picker.
  - Tap the [OK] button. The calibration curve within this date range will be displayed in the [Calibration] list.
- 5- In the [Calibration] list, check the radio button in front of the desired calibration curve.
- 6- When a confirmation message is displayed, tap [OK]. Tests calculated after this will be calculated using the new calibration curve.

## 7.7 View and apply calibration cutoff information

Different from the quantitative method which uses the calibration curve to calculate the concentration value, the qualitative method uses the cutoff value to determine whether a result is positive or negative. For assays validated on the analyzer using the qualitative method, the reagent kits manufacturer should edit corresponding assay parameter document and designate specific engineer to import the assays to the analyzer. After being imported on the analyzer, the comparator parameters can be viewed on the [Curves] screen under the [QC/CAL] main menu and be used for result determination.

### 7.7.1 View the calibration cutoff information

- 1- On the main menu, tap [QC/CAL].
- 2- On the submenu, tap [Curves].
- 3- At the bottom of the [Curves] screen, tap the [Search] button.
- 4- In the flyout:
  - Select the assay from the [Assay] drop-down list.
  - Select the date range from the [Date Range] date picker.
  - Tap the [OK] button. The cutoff information within this date range will be displayed in the [Calibration] list.
- 5- From the [Calibration] list, select a calibration cutoff information. The detail of the cutoff information can be viewed in [Comparator Parameters] and [Comparator Data].

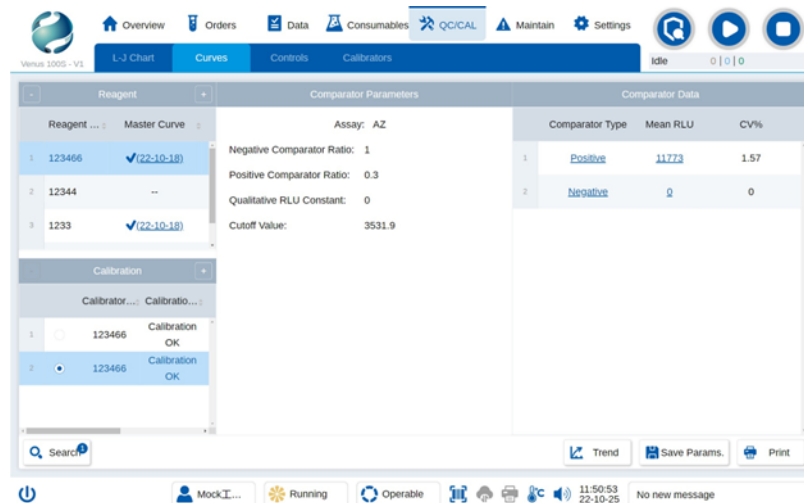

Figure: [Comparator Parameters] screen

### 7.7.2 Switch and apply the calibration cutoff information

- 1- On the main menu, tap [QC/CAL].
- 2- On the submenu, tap [Curves].
- 3- At the bottom of the [Curves] screen, tap the [Search] button.
- 4- In the flyout:
  - Select the assay from the [Assay] drop-down list.
  - Select the date range from the [Date Range] date picker.
  - Tap the [OK] button. The cutoff information within this date range will be displayed in the [Calibration] list.



- 5- In the [Calibration] list, check the radio button in front of the desired calibration cutoff information.
- 6- When a confirmation message is displayed, tap [OK]. Tests calculated after this will be calculated using the new cutoff information.

## Chapter 8 - Quality control procedures

Quality control is the process using controls of a known concentration to perform assays, after which quality control (QC) data is monitored and compared with the reference range described in the control product documentation to appraise and verify analysis bias caused by the change of reagent or analyzer. To ensure the performance of the analyzer, a quality control is suggested after calibration procedures, maintenance procedures or error handling procedures. The interval of required quality control is usually 24 hours. This parameter can be adjusted accordingly by changing the value of [Quality Control Interval] of [Consumables] settings on the [System] settings screen under the [Settings] main menu.

### 8.1 Control rule configuration

The user can set quality control rules for each assay individually. Please refer to "Assays" for details.

### 8.2 Input control information

#### 8.2.1 Add bar-coded control information

The information of the control will appear in the [Controls / Control Combinations] list on the [Controls] screen under the [QC/CAL] main menu with an [Opened Date] of the current time.

#### Scan the barcode with a barcode reader

- 1- Scan the barcode on the control information card with a barcode reader. The software will try to parse the barcode. If the information is parsed successfully, the [Edit Control] window will automatically display the detailed control information.
- 2- In the [Edit Control] window:
  - Tap the [OK] button to save the control information.
  - Tap the [Cancel] button to close the window without saving.

#### Input the barcode in the software user interface

- 1- On the bottom bar, tap the [Barcode] icon button.
- 2- In the flyout, input the barcode on the control information card. The software will try to parse the barcode. If the information is parsed successfully, the [Edit Control] window will automatically display the detailed control information.
- 3- In the [Edit Control] window:
  - Tap the [OK] button to save the control information.
  - Tap the [Cancel] button to close the window without saving.

#### 8.2.2 Add control information manually

The information of the control will appear in the [Controls / Control Combinations] list on the [Controls] screen under the [QC/CAL] main menu with an [Opened Date] of the current

time. The control will be marked with **M** after the name to indicate that the information was input manually.

- 1- On the main menu, tap [QC/CAL].
- 2- On the submenu, tap [Controls].
- 3- Under the [Controls / Control Combinations] list, tap the [Add] button to display the [Edit Control] window.
- 4- In the [Edit Control] window, fill in the detailed information on the control.
- 5- In the [Edit Control] window:
  - Tap the [OK] button to save the control information.
  - Tap the [Cancel] button to close the window without saving.
  - Tap the [Reset] button to clear the control information.

Basic Information				
Name	Lot	MFG Date	Shelf Life	
AZ-1				
EXP Date				
Concentration Data				
AZ				
Conc. Level	Mean	SD	Unit	
1 L1	0	0	mg/l	
2 L2	0	0	mg/l	

Figure: [Edit Control] window

### 8.2.3 View control information

- 1- On the main menu, tap [QC/CAL].
- 2- On the submenu, tap [Controls].
- 3- From the [Controls / Control Combinations] list, select a control in the [Controls / Control Combinations] list. The user can view the concentration value for each concentration level of the assay corresponding to the control in the [Concentration Data] table on the right side of the screen. The [Controls / Control Combinations] list displays the controls whose [Opened Date] are within the range set in [default time range for display] of the [Controls] settings on the [System] screen under the [Settings] main menu by default.
- 4- Under the [Controls / Control Combinations] list, tap the [Search] button to search for any previously saved control according to the conditions filled in.

- 5- Under the [Controls / Control Combinations] list, tap the [Print] button to print the selected controls in the [Controls / Control Combinations] list. If no control is selected, the whole list will be printed.

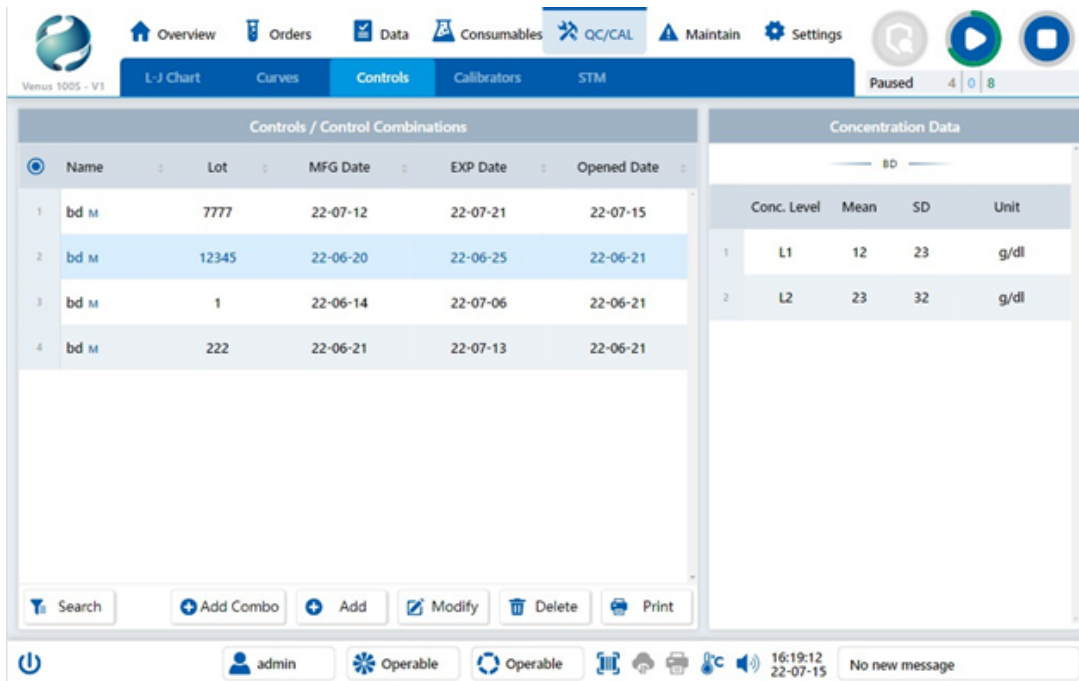

Figure: [Controls] screen

### 8.2.4 Modify control information

Only controls that are manually added can be modified.

- 1- On the main menu, tap [QC/CAL].
- 2- On the submenu, tap [Controls].
- 3- From the [Controls / Control Combinations] list, select a control that was marked with **M**.
- 4- Under the [Controls / Control Combinations] list, tap the [Modify] button to bring up the [Edit Control] window.
- 5- In the [Edit Control] window, modify the information of the control.
- 6- In the [Edit Control] window:
  - Tap the [OK] button to save the modification.
  - Tap the [Cancel] button to discard the modification.

### 8.2.5 Delete control information

Deleted controls can no longer be used for ordering new QC tests.

- 1- On the main menu, tap [QC/CAL].
- 2- On the submenu, tap [Controls].
- 3- From the [Controls / Control Combinations] list, select the control to be deleted.
- 4- Under the [Controls / Control Combinations] list, tap the [Delete] button.
- 5- When a confirmation message is displayed:
  - Tap the [OK] button to proceed with the deletion.

- Tap the [Cancel] button to cancel the deletion.

### 8.2.6 Add control combination

The control combination provides a convenient way to order QC tests for controls that are stored at fixed positions on the same rack. These controls can be preset as a control combination following the steps below. After the control combinations are created, when order control tests on the [Orders] - [Control] screen, the user can order tests for the controls together as a control combination all at once instead of filling in the sample information for each control. The added control combination will be displayed in the [Controls / Control Combinations] list. When a new control order is created, the control combination will also be available in the [Reference Materials] drop-down list.

- 1- On the main menu, tap [QC/CAL].
- 2- On the submenu, tap [Controls].
- 3- Under the [Controls / Control Combinations] list, tap the [Add Combo] button to bring up the [Edit Control Combination] window.
- 4- In the [Edit Control Combination] window, fill in the [Combination Name] and the [Control Rack].
- 5- In the [Edit Control Combination] window, select the constituent control stored on each position of the selected rack to fill in [Constituent Controls at Rack Positions].
- 6- In the [Edit Control Combination] window:
  - Tap the [OK] button to save the control combination.
  - Tap the [Cancel] button to close the window without saving.
  - Tap the [Reset] button to clear the control combination information.

The screenshot shows the 'Edit Control Combination' window. It features a title bar at the top. Below the title bar is a section titled 'Basic Information' containing two input fields: 'Combination Name' and 'Control Rack'. Below this is another section titled 'Constituent Controls at Rack Positions' which contains eight numbered input fields (1 through 8) for selecting controls. At the bottom of the window are three buttons: 'Reset', 'Cancel', and 'OK'.

Figure: [Edit Control Combination] window

## 8.3 Create control orders

### 8.3.1 Create an individual control order

- 1- On the main menu, tap [Orders].

- 2- On the submenu, tap [Control].
- 3- Under the control order list, tap the [Add] button.
- 4- In the sample editing area, select the control to be used from the [Reference Material] drop-down list. When there are other controls of the same lot number with different concentration levels, the analyzer will automatically select them in groups. The selection of a particular control can be canceled individually by tapping the [X] icon after the name of the control. When a control is selected, the reagent button associated with the control will be enabled, while the rest of the reagent buttons will be disabled.
- 5- In the sample editing area, select the rack number and position from the [Rack Position] drop-down list according to the position of the control on the sample rack. [Rack Position] can be left blank when the control is labeled with a barcode. If neither the control nor the sample rack has a barcode, or the scanner is not functioning, then [Carousel Position] needs to be filled in:
  - In the sample editing area, select from the [Carousel Position] drop-down list where the control is located on the carousel.
- 6- Among the reagent buttons, tap the target reagent button to add control tests.
- 7- Under the sample editing area, tap [Save] to submit the control order.

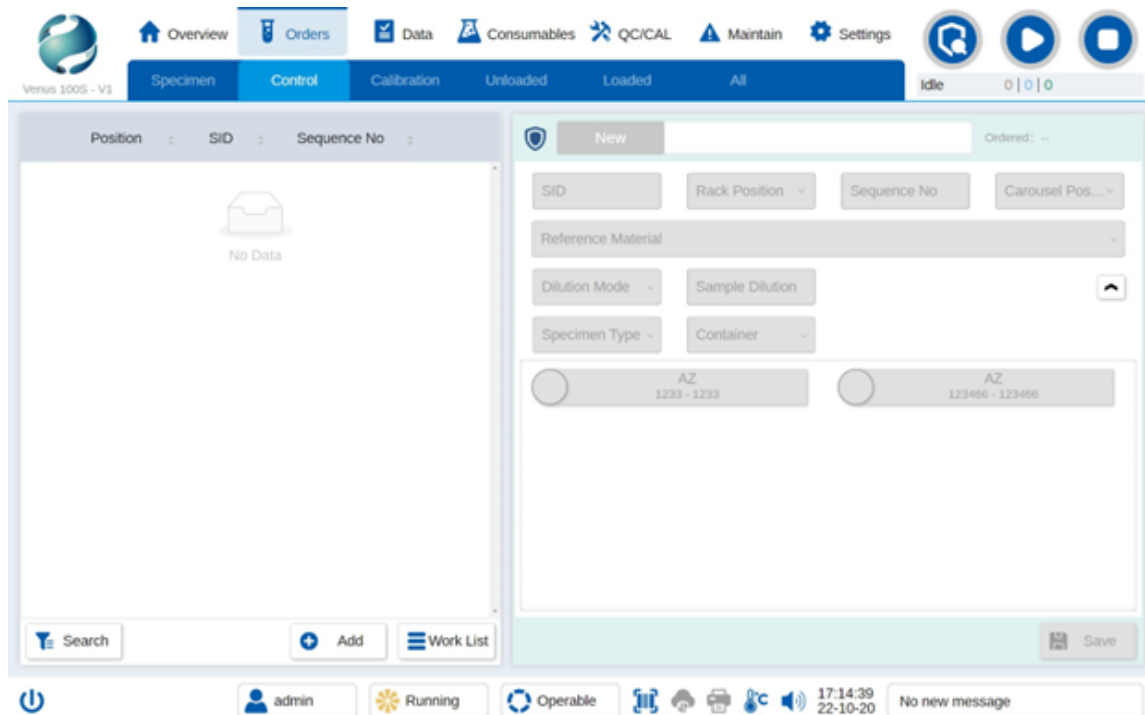

Figure: [Control] screen under the [Orders] main menu

### Create orders for a control combination

- 1- On the main menu, tap [Orders].
- 2- On the submenu, tap [Control].
- 3- Under the control order list, tap the [Add] button.
- 4- In the sample editing area, select the name of the control combination to be used from the [Reference Material] drop-down list. When a control combination is selected, the reagent button associated with the control will be enabled, while the rest of the reagent buttons will be disabled. The analyzer software will automatically fill in the [Rack Position] for each of the control in this combination based on the preset information.

- 5- Among the reagent buttons, tap the target reagent button to add control tests.
- 6- Under the sample editing area, tap [Save] to submit the control order. The analyzer software will create multiple control tests based on the selected reagent. When there is more than one control that is available for the control test for the same concentration level of the same reagent, only one control test will be created. When the controls are not related to the selected reagent, no control test will be created.

#### 8.4 Shortcut to create control orders for onboard reagents

For the reagents installed on the analyzer, the analyzer software provides an easy way to order control tests. Unlike the regular way to order control tests on the [Control] screen under the [Orders] main menu, the shortcut to order control tests is on the [Reagents] screen under the [Consumables] main menu, allowing the user to order control tests with a clear view of the reagent status.

- 1- On the main menu, tap [Consumables].
- 2- On the submenu, tap [Reagents].
- 3- From the reagents list, select the reagents to be controlled or proceed to the next step without selection.
- 4- Under the reagents list, tap the [Order QC] button to bring up the [Order Control Tests] window. The [Order Control Tests] window lists the selected reagents. If no reagent is selected, all onboard reagents whose control status is not [OK] will be listed. The checkbox will be checked in front of the reagents that need to be controlled. The user can change the control test details by expanding the reagents tree view and modifying the detail information. The user can tap [Expand All], [Collapse All], [Collapse unQCed] and [Expand unQCed] buttons to quickly expand and collapse the list.
- 5- In the [Order Control Tests] window:
  - Tap the [OK] button to order all the checked control tests.
  - Tap the [Cancel] button to discard the current operation.

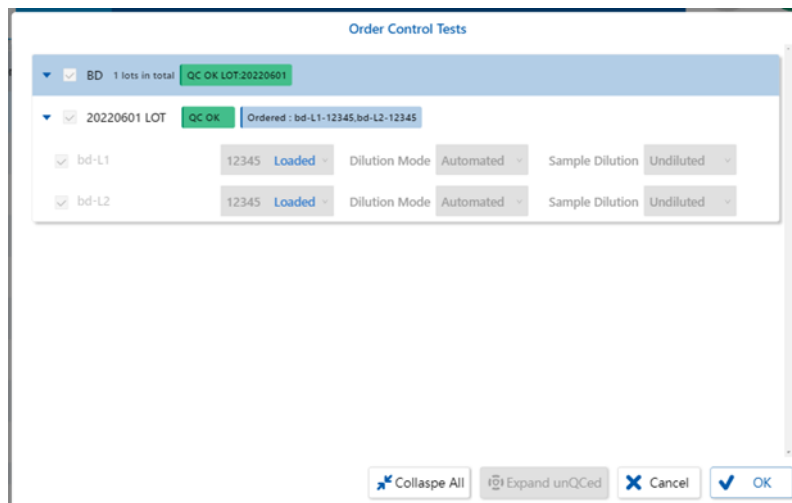

Figure: [Order Control Tests] window

#### 8.5 View the Levey-Jennings chart

##### 8.5.1 Display the Levey-Jennings chart for an assay

- 1- On the main menu, tap [QC/CAL].
- 2- On the submenu, tap [L-J Chart].
- 3- In the [Search QC Data] panel, select the target assay in the [Assay] drop-down list.

- 4- In the [Search QC Data] panel, select the control in the [Control-Lot] drop-down list.
- 5- In the [Search QC Data] panel, select the date range in the [Date Range] date picker. The default setting for the date range is 30 days.
- 6- In the [Search QC Data] panel, check the [Conc. Level] checkbox to search for control data of specific concentration levels.
- 7- In the [Search QC Data] panel, tap the [Search] button. All QC curves within this time range will be displayed in the [L-J Chart] on this page. Any violation of the control rule will be displayed in the [Violations] panel.

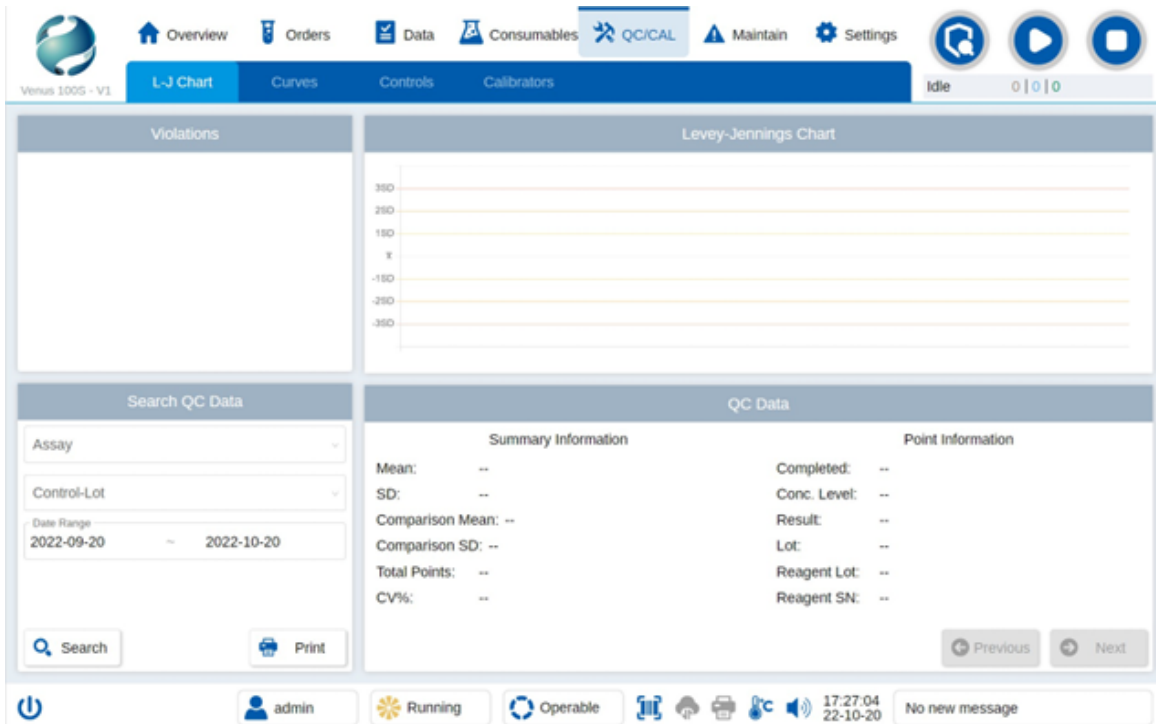

Figure: [L-J Chart] screen

### 8.5.2 View the Levey-Jennings point details

- 1- Tap a point on the [L-J Chart].
- 2- In the [QC Data] module, the [Summary Information] and [Point Information] for the control point will be displayed.
- 3- At the bottom of the [QC Data] module:
  - Tap the [Previous] button to view the previous control point information.
  - Tap the [Next] button to view the next control point information.

## Chapter 9 - Specimen order procedures

### 9.1 Create specimen orders

#### 9.1.1 Manually create specimen test orders

When manually ordering specimen tests, the user can order an individual specimen test or order multiple specimen tests in batch editing mode.

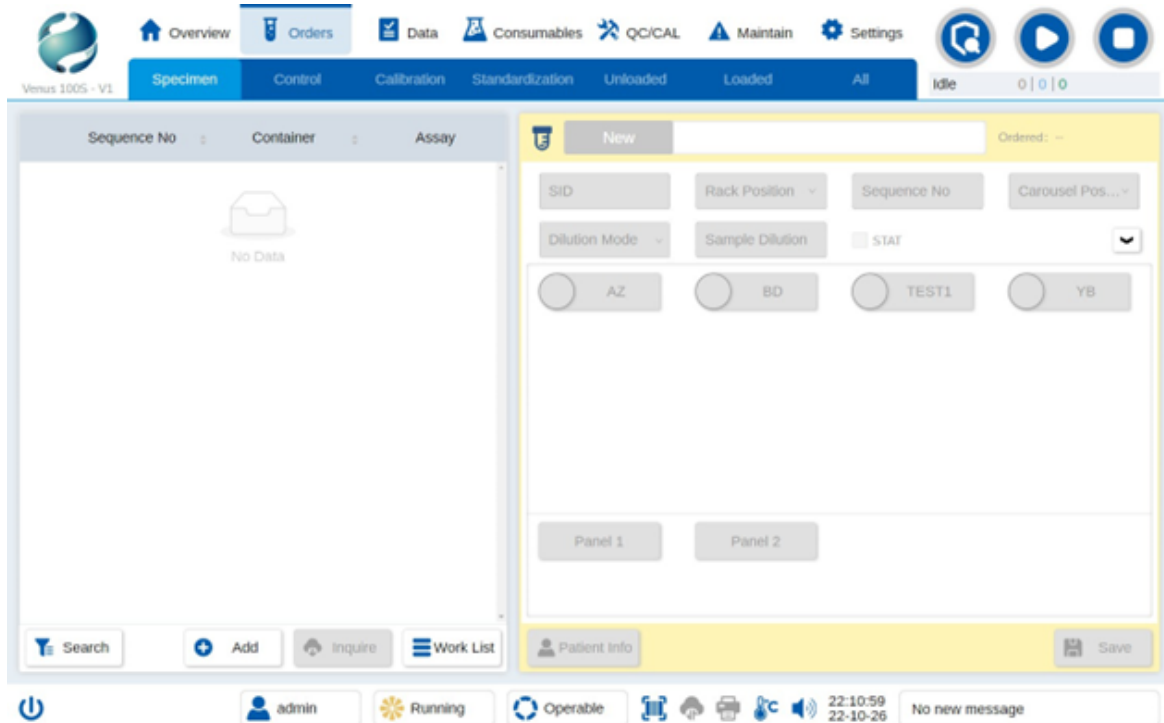

Figure: [Specimen] screen under the [Orders] main menu

### Order an individual specimen test

- 1- On the main menu, tap [Orders].
- 2- On the submenu, tap [Specimen].
- 3- Under the specimen orders list, tap the [Add] button.
- 4- In the sample information area:
  - In the [SID] text box, enter the Specimen ID.
  - From the [Rack Position] drop-down list, select the sample rack number and the position based on the actual position of the specimen. [Rack Position] and [Carousel Position] can be left blank when there is a barcode attached to the specimen. [Carousel Position] is required only when neither the specimen nor the sample rack has a barcode, or when the barcode reader is experiencing function failure. The [Carousel Position] can to be filled in by tapping on the [Carousel Position] drop-down list, and selecting the carousel number and position number based on the actual position of the specimen on the carousel.
  - In the [Sequence No.] text box, enter the specimen sequence number. The number can be generated automatically based on [Auto Sequence Number Format] if [Automatic Sequence Number] of the [Specimens] settings on the [System] screen under the [Settings] main menu is enabled.
  - From the [Dilution Mode] drop-down list, select the specimen dilution mode.
  - In the [Sample Dilution] text box, input the specimen dilution factor.



- Check the [STAT] checkbox if this sample requires priority processing.
  - Tap the [Expand/Collapse] icon button to display more specimen settings.
- 5- Among the assay buttons:
    - Toggle the selection of the square button of an assay to add or remove a test.
    - Tap the round button of the assay to display the [Test Options] window.
  - 6- In the [Test Options] window, the user can modify the [Dilution], [Number of Replicates], [Reagent Lot], and [Reagent SN] for each test.
  - 7- Among the assay panel buttons, tap the assay panel to add tests for each assay included in the assay panel.
  - 8- Under the sample editing area, tap the [Save] button to save the specimen information. If the specimen is labeled with a barcode, and both [Rack Position] and [Carousel Position] are left empty, the specimen can be placed at any empty position on the sample carousel. Otherwise, the specimen needs to be placed at the sample rack position exactly as the [Rack Position] selection and the [Carousel Position] selection.

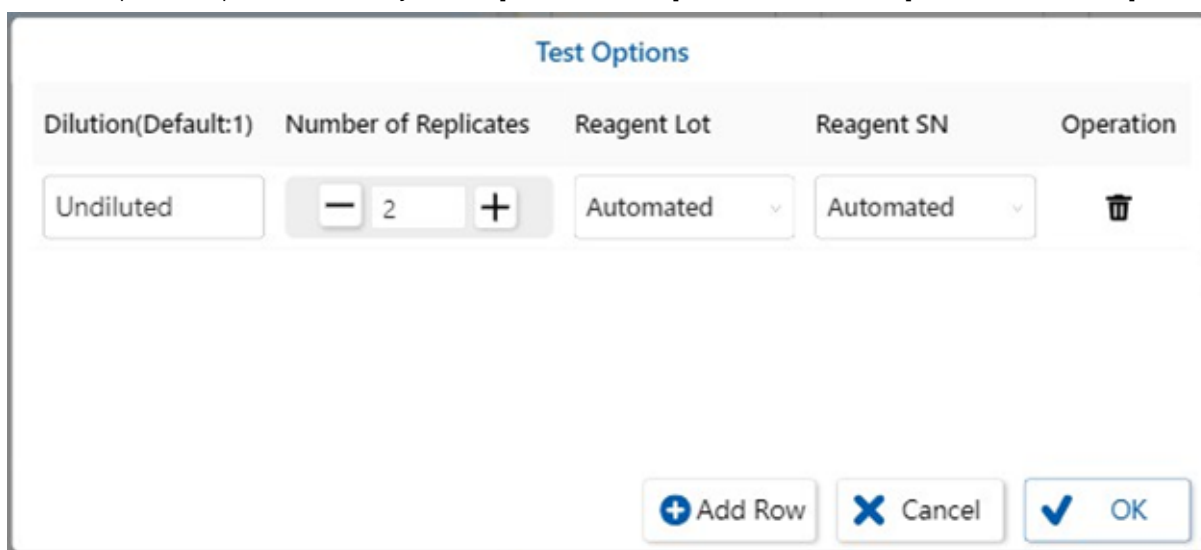





Figure: [Test Options] window

### Batch specimen test ordering

When specimen orders are created in the batch order mode, the specimen information are the same for all specimens in this batch except for [SID], [Rack Position], [Sequence No], and [Carousel Position].

- 1- On the main menu, tap [Orders].
- 2- On the submenu, tap [Specimen].
- 3- Under the specimen orders list, tap the [Add] button.
- 4- At the top-left corner of the sample editing area, tap the [Specimen] icon button  to switch to batch editing mode.
- 5- In the sample information area, tap the [Batch Edit] icon button  located at the right corner inside [SID], [Rack Position], [Sequence Number] and [Carousel Position] to display the [Batch Edit] window.
- 6- In the [Batch Edit] window:

- Tap the [Add Row] button to add multiple sample rows, or enter multiple sample information in one cell based on the advanced batch information parsing rule. The analyzer will automatically overwrite the current cell and the cells after if the input information is successfully parsed. If the number of rows is not enough, the software will automatically add new rows.
  - Tap the [Save] button to save the changes and close the window.
  - Tap the [Cancel] button to discard the changes and close the window.
- 7- In the sample information area:
- From the [Dilution Mode] drop-down list, select the specimen dilution mode.
  - In the [Sample Dilution] text box, input the specimen dilution factor.
  - Check the [STAT] checkbox if this batch of samples requires priority processing.
  - Tap the [Expand/Collapse] icon button  to display more specimen settings.
- 8- Among the assay buttons:
- Toggle the selection of the square button of an assay to add or remove a test.
  - Tap the round button of the assay to display the [Test Options] window.
- 9- In the [Test Options] window, the user can modify the [Dilution], [Number of Replicates], [Reagent Lot], and [Reagent SN] for each test.
- 10- Among the assay panel buttons, tap the assay panel to add tests for each assay included in the assay panel.
- 11- Under the sample editing area, tap the [Save] button to save the specimen information. If the specimen is labeled with a barcode, and both [Rack Position] and [Carousel Position] are left empty, the specimen can be placed at any empty position on the sample carousel. Otherwise, the specimen needs to be placed at the sample rack position exactly as the [Rack Position] selection and the [Carousel Position] selection.

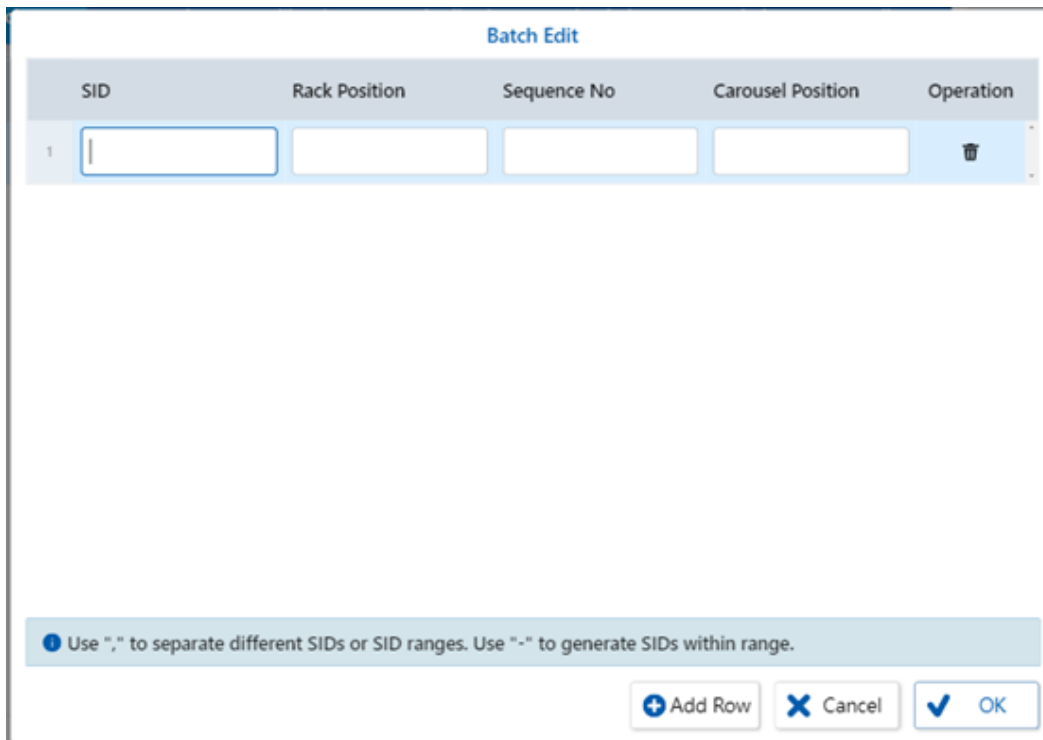

Figure: [Batch Edit] window

### 9.1.2 Inquire specimen test orders via network

The analyzer supports automatic and manual inquiry of specimen order information from the LIS server.

#### Automatic inquiry

When both the scanner and the LIS connection are functioning properly, the analyzer can read the barcode on the specimen and inquire the test order information from the LIS server and create the specimen test orders.

- 1- Place the bar-coded specimens in the sample carousel.
- 2- At the top-right corner of the screen, tap the [Start/Pause] icon button. The analyzer will scan the specimen barcodes, inquire for the specimen information from the LIS server, create specimen test orders and then perform the specimen test procedure.

#### Manual inquiry

- 1- On the main menu, tap [Orders].
  - 2- On the submenu, tap [Specimen].
  - 3- Under the specimen orders list, tap the [Inquire] button.
  - 4- In the flyout, select the inquiry option radio button:
    - [Inquire by Sequence Number]: Enter the sequence number in the text box, and then the analyzer will download the order information for the specified specimen from the LIS server.
    - [Inquire by SID]: Enter the SID in the text box, and the analyzer will download the order information for the specified specimen from the LIS server.
  - 5- In the flyout, tap the [OK] button.
- 6-Select the specimen in the specimen orders list and verify the specimen information, test information, and patient information in the sample editing area.

## 9.2 Patient information

### 9.2.1 View and edit patient information

Patient information can be obtained from the LIS server. The user can also fill in patient information in the software and upload the patient information to the LIS server.

- 1- On the main menu, tap [Orders].
- 2- On the submenu, tap [Specimen].
- 3- From the specimen orders list, select a specimen order.
- 4- Under the sample editing area, tap the [Patient Info] button to bring up the [Patient Info] window.
- 5- In the [Patient Info] window, the user can view and edit the patient information.
- 6- In the [Patient Info] window:
  - Tap the [OK] button to save the changes and close the window
  - Tap the [Cancel] button to discard the changes and close the window.

Figure: [Patient Info] window

## Chapter 10 - Sample management

### 10.1 Addition, deletion and modification of sample tests

Ordering additional tests is allowed for samples in any state. Modification of sample information is allowed when none of the assays has started, i.e., when the sample is in [NTA], [TBL], and [Pending] status. In other sample statuses, the user is only allowed to modify the tests that are in the [Pending] status or add new tests to a sample. A test can be deleted before the test process starts. Only tests in the [Pending] state can be deleted. Tests in the [Running] or [Completed] status cannot be deleted by editing the sample tests.

#### 10.1.1 Individual editing of a sample order

- 1- On the main menu, tap [Orders].
- 2- On the submenu, tap [All] or another submenu according to the target sample type.
- 3- Under the sample order list, tap the [Search] button.
- 4- In the flyout, enter the filtering conditions.
- 5- In the flyout, tap the [OK] button. Samples that fit the conditions will be displayed in the sample order list.
- 6- In the sample order list, select the sample order to be edited. Verify the information of the sample in the sample editing area. If the sample editing area is not displayed, tap the [Edit Mode] button at the bottom-right corner of the sample list to switch to the sample editing view.
- 7- Among the assay panel buttons, tap the assay panel to add tests for each assay included in the assay panel.
- 8- Among the assay buttons:
  - Toggle the selection of the square button of an assay to add or remove a test.
  - Tap the round button of the assay to display the [Test Options] window.
  - In the [Test Options] window, the user can modify the [Dilution], [Number of Replicates], [Reagent Lot], and [Reagent SN] for each test.
- 9- In the [Test Options] window:
  - Tap the [OK] button to save the test information of an assay.

- Tap the [Cancel] button to discard the changes of an assay.
- 10- Under the sample editing area, tap the [Save] button to save the changes to the sample.

### 10.1.2 Batch editing of sample orders

In the batch editing mode, the user can edit the tests of multiple sample orders together. When orders of the same sample category (e.g., all orders selected are specimen or control orders) are selected from the sample order list on the [All] screen or another submenu screen under the [Orders] main menu, the batch editing mode will be enabled.

- 1- On the main menu, tap [Orders].
- 2- On the submenu, tap [All] or another submenu according to the target sample type.
- 3- Under the sample order list, tap the [Search] button.
- 4- In the flyout, enter the filtering conditions.
- 5- In the flyout, tap the [OK] button. Samples that fit the conditions will be displayed in the sample order list.
- 6- At the top-left corner of the sample order list, tap the [Selection Mode] icon button to switch to [Multiple Selection] mode.
- 7- In the sample order list, select samples to be edited. On the round button of an assay:
  - A solid “√” icon will be displayed when an assay is ordered for all samples.
  - A dashed “√” icon will be displayed When an assay is ordered for only some of the samples.
  - An empty content will be displayed when an assay is not ordered for any sample.
- 8- Among the assay panel buttons, tap the assay panel to add tests for each assay included in the assay panel.
- 9- Among the assay buttons:
  - Toggle the selection of the square button of the assay to add or remove a test.
  - Tap the round button of the assay to display the [Test Options] window.
- 10- In the [Test Options] window, the user can modify the [Dilution], [Number of Replicates], [Reagent Lot], and [Reagent SN] for each test.
- 11- In the [Test Options] window:
  - Tap the [OK] button to save the test information of an assay.
  - Tap the [Cancel] button to discard the changes of an assay.
- 12- Under the sample editing area, tap the [Save] button to save the changes to the sample.

## 10.2 Sample loading and unloading

Sample loading refers to the process of assigning a [Carousel Position] to a sample. The analyzer will identify the samples whose [Carousel Position] are not empty as onboard. On the [Loaded] screen under the [Orders] main menu, the user can view all onboard samples in the analyzer. On the [Unloaded] screen under the [Orders] main menu, the user can view all samples that are not onboard. Each [Carousel Position] can only be assigned to one sample at the same time.

### 10.2.1 Automatic loading and unloading

With the assistance of the built-in barcode reader, the analyzer will automatically set [Carousel Position] for samples placed on the sample carousel and clear the [Carousel Position] for samples removed from the sample carousel that fit the description below:

- Samples labeled with a barcode.
- Samples on a sample rack that is labeled with a barcode.

### 10.2.2 Manual loading and unloading

Manual loading and unloading of samples are required when neither the sample nor the sample rack has a barcode, or no scanner is installed. Sample loading and unloading are not allowed when the analyzer is in the [Running] state.

#### Manual loading sample

- 1- On the main menu, tap [Orders].
- 2- On the submenu, tap [Unloaded].
- 3- Select an individual sample in the [Individual Selection] mode or select multiple samples to be loaded in the [Multiple Selection] mode.
- 4- In the sample editing area, tap the [Carousel Position] drop-down list to assign [Carousel Position] to the selected samples.
- 5- Under the sample editing area, tap the [Save] button to save [Carousel Position].

#### Manual unloading sample

- 1- On the main menu, tap [Orders].
- 2- On the submenu, tap [Loaded].
- 3- Select an individual sample in the [Individual Selection] mode or select multiple samples to be loaded in the [Multiple Selection] mode.
- 4- Under the sample editing area, tap the [Unload] button.
- 5- When a confirmation message is displayed, tap the [Save] button, and the [Carousel Position] will be cleared manually.

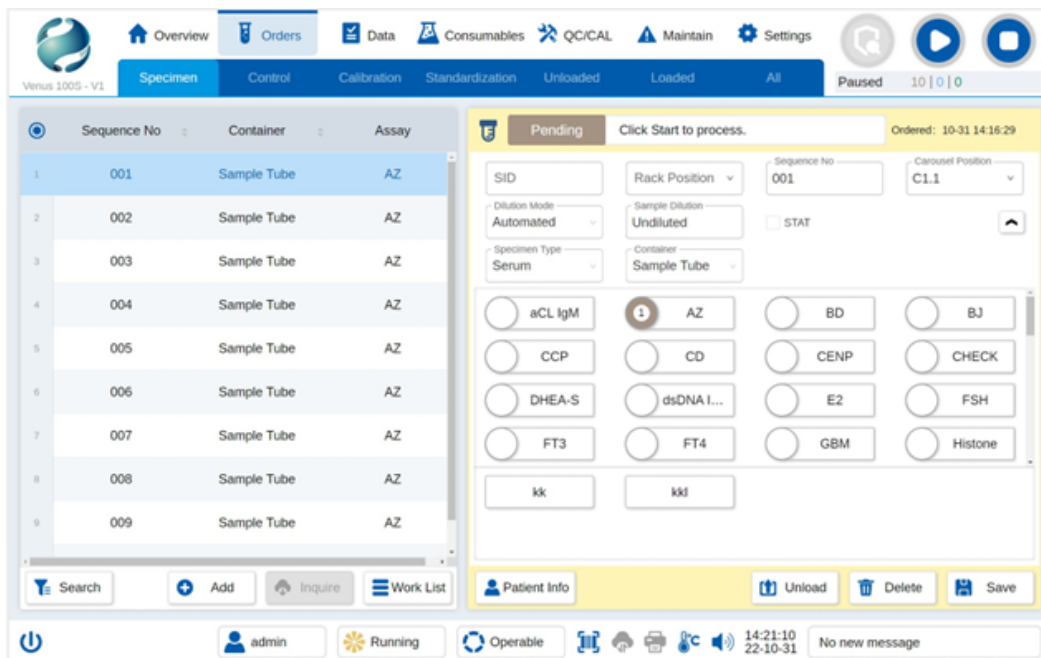

Figure: [Individual Selection] mode

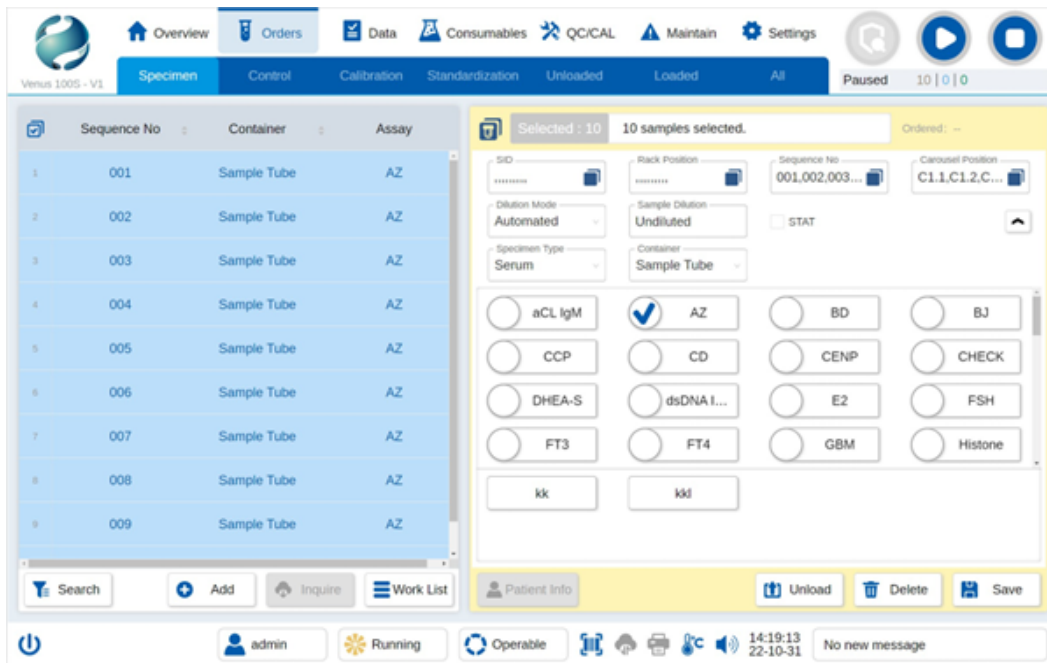

Figure: [Multiple Selection] mode

### 10.3 Deletion of sample

A sample can only be deleted when no test of the sample has started processing or all tests of the sample has finished processing, i.e., when the sample status is [NTA], [TBL], [Pending], and [Completed]. After a sample is deleted, both the order information and test results are deleted. The operation of sample deletion will be recorded in the [Edits] log on the [Log] screen under the [Maintain] main menu.

- 1- On the main menu, tap [Orders].
- 2- On the submenu, tap [All] or another submenu according to the target sample type.
- 3- Under the specimen order list, tap the [Search] button.
- 4- In the flyout, enter the filtering conditions.
- 5- In the flyout, tap the [OK] button. Samples that fit the conditions will be displayed in the sample order list.
- 6- Select an individual sample in the [Individual Selection] mode or select multiple samples to be deleted in the [Multiple Selection] mode.
- 7- Under the sample editing area, tap the [Delete] button.
- 8- When a confirmation message is displayed, tap the [OK] button, and selected samples will be deleted.

### 10.4 Sample order selection

After scanning barcodes on sample containers or sample racks, the software will search from the database to find the sample orders that match the sample information. If two or more sample orders are matched, the software will display the [Select Sample] window, in which the option that matches the [default primary keyword for sample order Selection] will be selected by default. The matching keyword options include [SID], [Rack Position], and [Carousel Position]. Users can select from the matched options to bind with the current sample, add a new order for the current sample, or skip the selection for now to deal with it later. Before the sample information is confirmed, no test will be processed.

### 10.4.1 Select a sample order

- 1- In the [Select Sample] window, tap the  icon button to expand the list for all available sample order options.
- 2- In the expanded list, all available sample options with sample details will be displayed, as well as the [New] and [Ignore] options:
  - Tap the radio button of any sample orders to bind the current sample.
  - Tap the radio button of [New] to create a new sample order for the current sample.
  - Tap the radio button of [Ignore] to skip the selection for now and deal with it later.
- 3- In the [Select Sample] window:
  - Tap the [OK] button to close the window and apply the sample order selection.
  - Tap the [Cancel] button to close the window and skip the sample order selection for all samples.

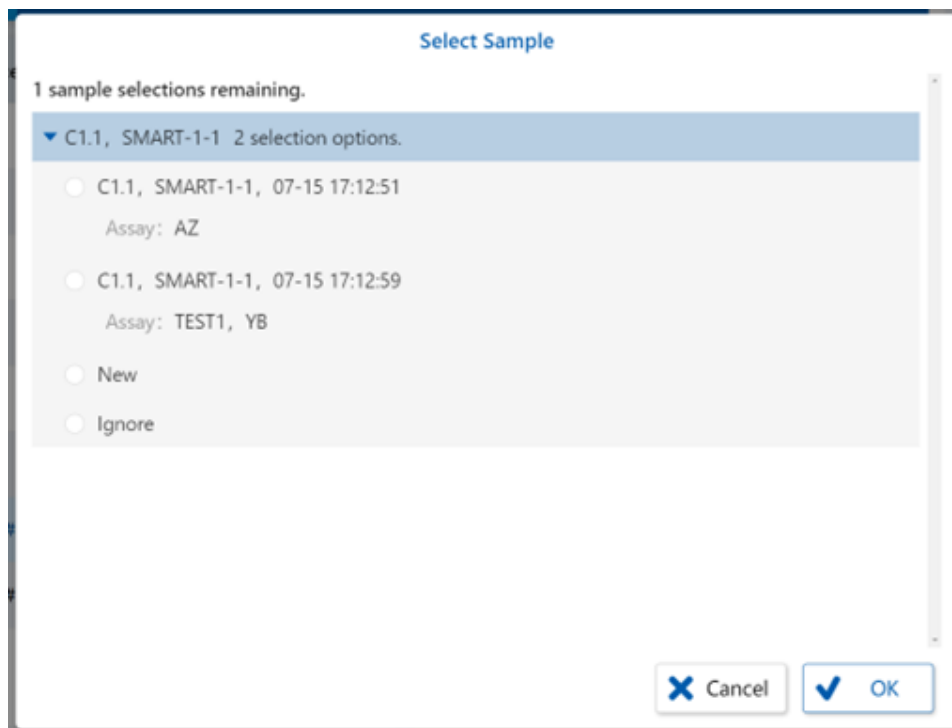

Figure: [Select Sample] window



## Chapter 11 - Data handling

### 11.1 View data

#### 11.1.1 View test information

The user can view the test information. The [Test Status] includes the following: [Pending], [Running] and [Completed]. When tests are in the [Completed] status, the color of the [Test Status] icon is defined as following:

Icon Color	Definition
Green	No exception happened during the test process and the test result is within the normal reference range.
Yellow	No exception happened during the test process but the test result falls outside the normal reference range.
Red	At least one exception happened during the test process. The user should determine if a rerun is needed based on the exception detail.

Tap the [Data] menu to select different submenus to view test information from different perspectives. All screens of the submenu display tests of the current day by default. To view the historical test data, tap the [Search] button to add search conditions. The table columns displayed can be customized by setting the visibility and the order of each information column on the [Table] screen under the [Settings] main menu.

#### View all tests

The tests are displayed in descending order of test creation time by default, i.e., the most recently ordered tests are in the first row, and the earliest ordered tests are in the last row.

- 1- On the main menu, tap [Data].
- 2- On the submenu, tap [Test].
- 3- In the test list, all tests ordered and tested on that day will be displayed.

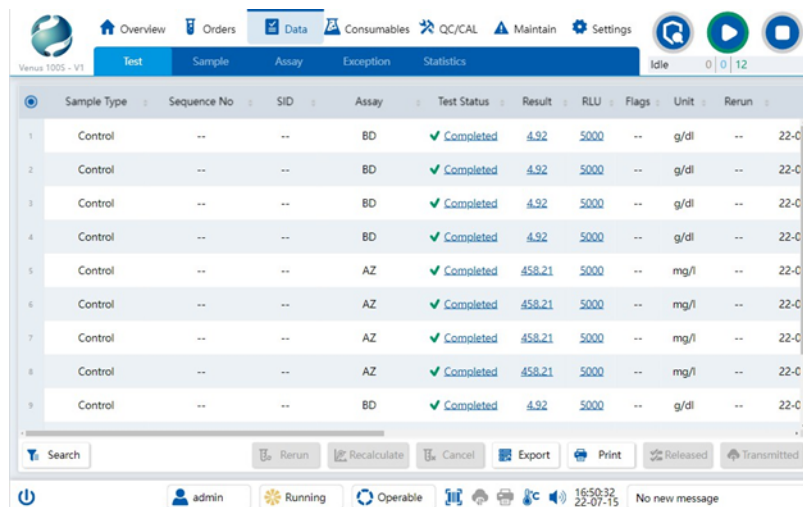

Figure: [Test] screen under the [Data] main menu

#### View tests by sample

The user can view the tests grouped by each sample.

- 1- On the main menu, tap [Data].
- 2- On the submenu, tap [Sample]. [Samples] list will display all samples ordered and tested on the current day.

- From the [Samples] list, select a sample, and the [Tests] list will display all tests of the selected sample with detailed test information.

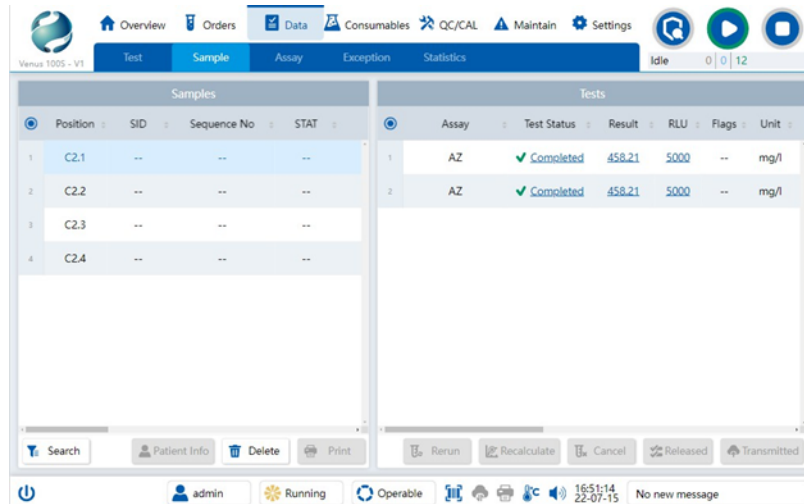

Figure: [Sample] screen under the [Data] main menu

### View tests by assay

The user can view tests grouped by each assay.

- On the main menu, tap [Data].
- On the submenu, tap [Assay].
- From the [Assays] list, select an assay name, and the tests of the selected assay will be displayed in the [Tests] list.

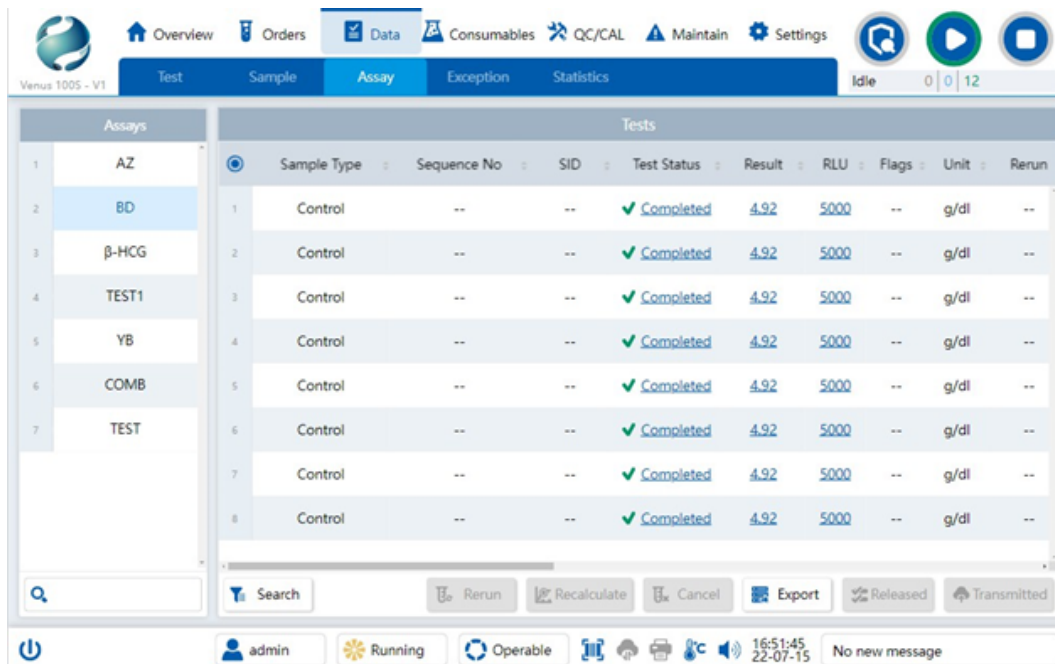

Figure: [Assay] screen under the [Data] main menu

### 11.1.2 View statistics

#### View the total number of specimen tests

The analyzer counts the total number of tests performed on a specimen for all assays. The user can view this data within any specified date range.

- 1- On the main menu, tap [Data].
- 2- On the submenu, tap [Statistics].
- 3- From the tabs, tap [Specimen Tests].
- 4- The table will show all samples currently ordered with the total test count.

Ordered	Sequenc...	SID	Total Tests	Immunoassay...	Calculated Te...
1	22-07-15 13:33:55	--	2	2	0
2	22-07-15 13:33:54	--	2	2	0
3	22-07-15 12:27:50	--	4	4	0
4	22-07-15 12:27:49	--	4	4	0
5	22-07-12 17:44:05	--	2	2	0
6	22-07-12 17:44:05	--	2	2	0
7	22-07-12 14:34:36	--	2	2	0
8	22-07-12 14:34:36	--	2	2	0
9	22-07-12 14:34:36	--	4	4	0

Figure: [Specimen Tests] in the [Statistics] screen under the [Data] main menu

### View the total number of assay tests

The analyzer counts the number of tests of each assay for specimen tests. The user can view this data within any specified date range.

- 1- On the main menu, tap [Data].
- 2- On the submenu, tap [Statistics].
- 3- From the tabs, tap [Assay Tests].
- 4- The table will show the number of tests ordered and the number of tests completed for each assay. Calibration tests and control tests are not included in these statistics.

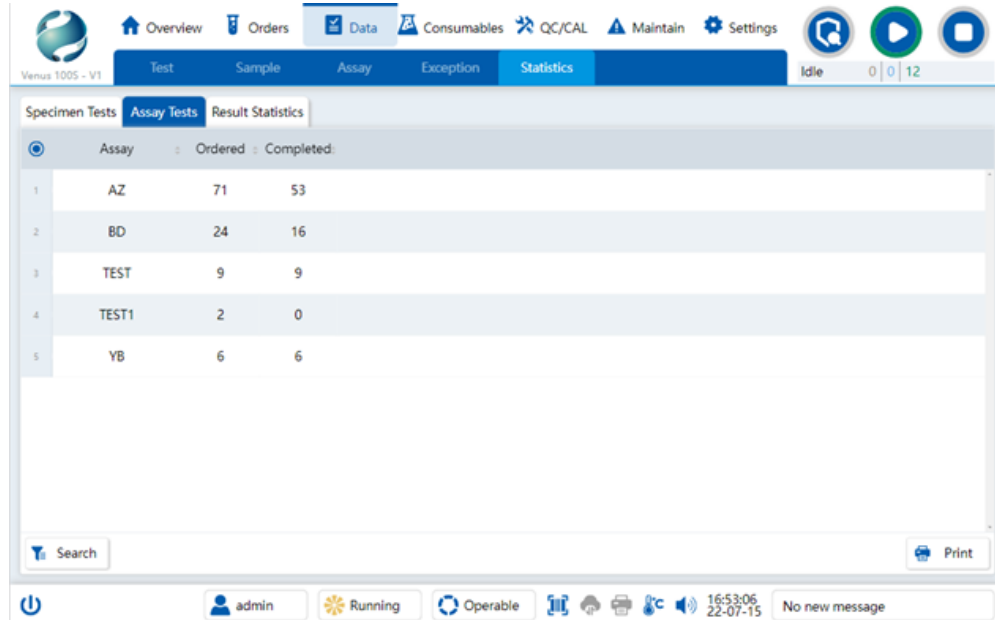

Figure: [Assay Tests] in the [Statistics] screen under the [Data] main menu

### View result statistics of assay tests

The analyzer collects the test results for each assay and generates the trend of the distribution of test results for all specimens. The user can view this data within any specified date range and print statistical data and statistical graphs.

- 1- On the main menu, tap [Data].
- 2- On the submenu, tap [Statistics].
- 3- From the tabs, tap [Result Statistics].
- 4- Under the [Statistics Summary], tap the [Search] button.
- 5- In the flyout, enter and select filtering conditions.
- 6- In the flyout, tap the [OK] button. In the [Statistics Summary], [Assay], [Total Tests], [Mean], [SD], [Max], [Min], and [CV%] will be displayed. And in the [Statistics Data], the detailed test information will be displayed.
- 7- Under the [Statistics Data]:
  - Tap the [Graph] button to view the statistical graph, and the content of the button will change to [Statistics Data].
  - Tap [Statistics Data] button to view the statistics data, and the content of the button will change to [Graph].

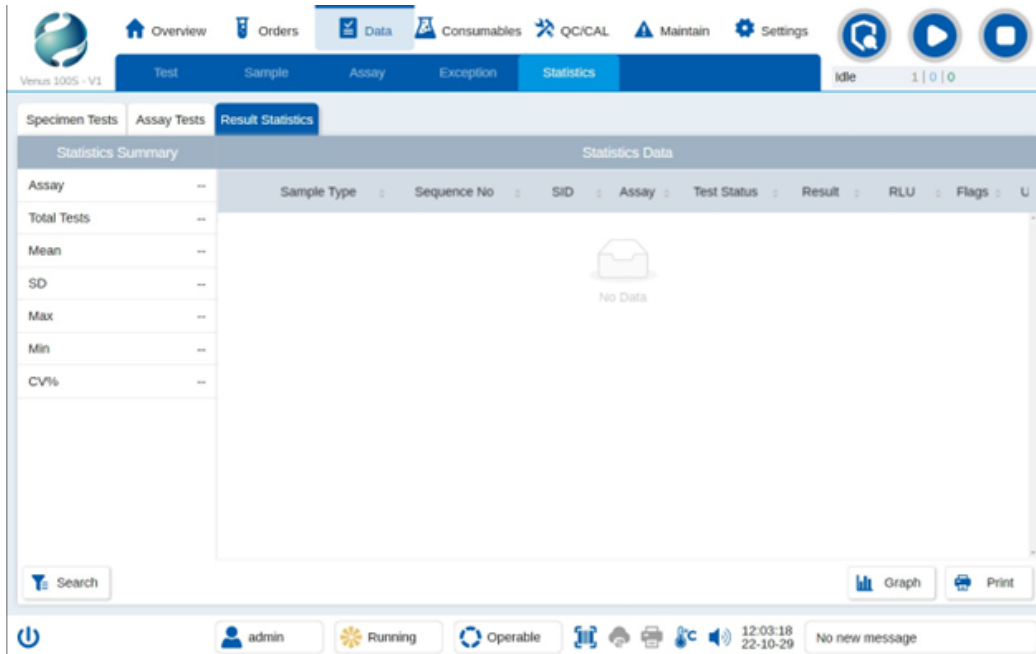

Figure: [Result Statistics] in the [Statistics] screen under the [Data] main menu

### 11.1.3 View test exceptions

Exceptions refer to tests with anomalies in the testing process. By default, tests are displayed in descending order of order time, i.e., the most recently ordered test is in the first line, and the earliest ordered test is in the last line.

- 1- On the main menu, tap [Data].
- 2- On the submenu, tap [Exception].
- 3- The screen will display all test ordered and tested of the current day that had anomalies.

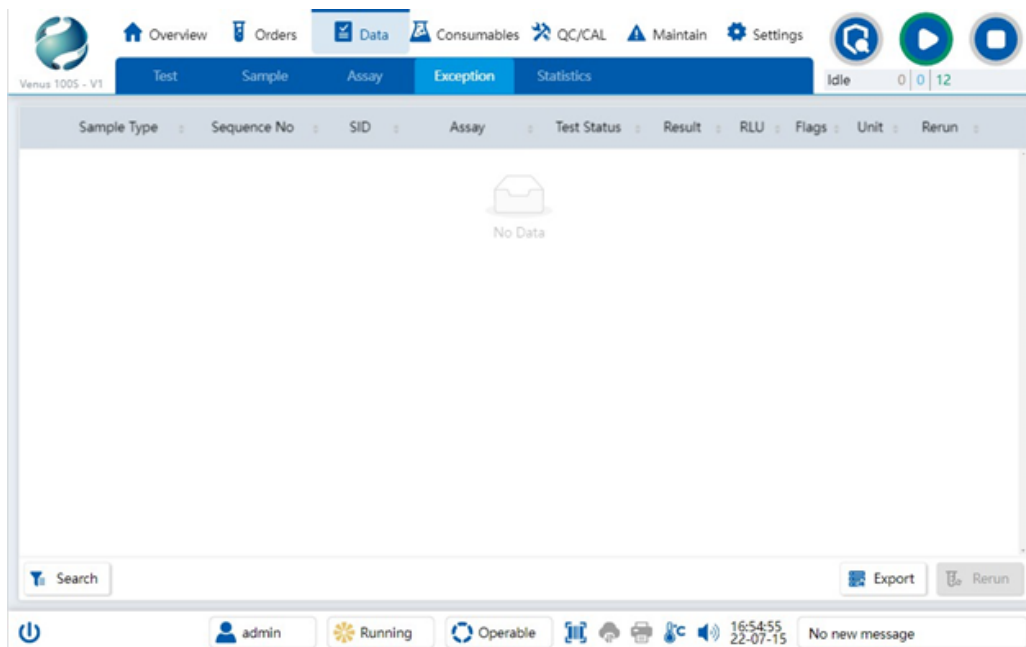

Figure: [Exception] screen under the [Data] main menu

## 11.2 Create rerun orders

After a test is completed, it can be rerun manually or automatically. The user can perform a manual rerun on the [Test] screen, [Exception] screen, [Sample] screen, and [Assay] screen under the [Data] main menu by selecting the tests with the status of [Completed] and specifying the test options. When the test results meet any retest rules in [Retest Rule], the analyzer will automatically rerun the test.

### 11.2.1 Automated retest

After the test is completed, the analyzer will evaluate whether the test result meets the retest rule. If it does, a rerun order will be automatically generated. Please refer to "Assay Configuration" for more information about setting up an automated retest.

### 11.2.2 Manual retest

- 1- On the main menu, tap [Data].
- 2- On the submenu, tap [Test], [Exception], [Sample] or [Assay].
- 3- From the test list, select one or more tests to be retested.
- 4- Under the test list, tap the [Rerun] button to bring up the [Rerun] window.
- 5- In the [Rerun] window, specify test options for the rerun tests.
- 6- In the [Rerun] window, tap the [OK] button.
- 7- Place the sample to be retested on the sample carousel and tap the [Start/Pause] button to start the retest.

Sequence...	SID	Assay	Test Dilution	Number of Re...	Reagent Lot	Reagent SN
1	--	BD	Undiluted	- 1 +	20220601	2

Cancel OK

Figure: [Rerun] window

### 11.2.3 View and select retest results

When an assay of a sample has been retested manually or automatically, you can view all the test results on the [Sample] screen under the [Data] main menu and select any of the retest results as the default result of the assay.

- 1- On the main menu, tap [Data].
- 2- On the submenu, tap [Sample].
- 3- From the [Samples] list, select a sample.
- 4- From the [Tests] list, select a test.

- 5- From the [Tests] list, tap the  button to expand all retest results of a test. By default, the most recent retest result is selected as the current result of the assay test.
- 6- On the left of the test information row, tap the radio button to set the retest result as the current result.

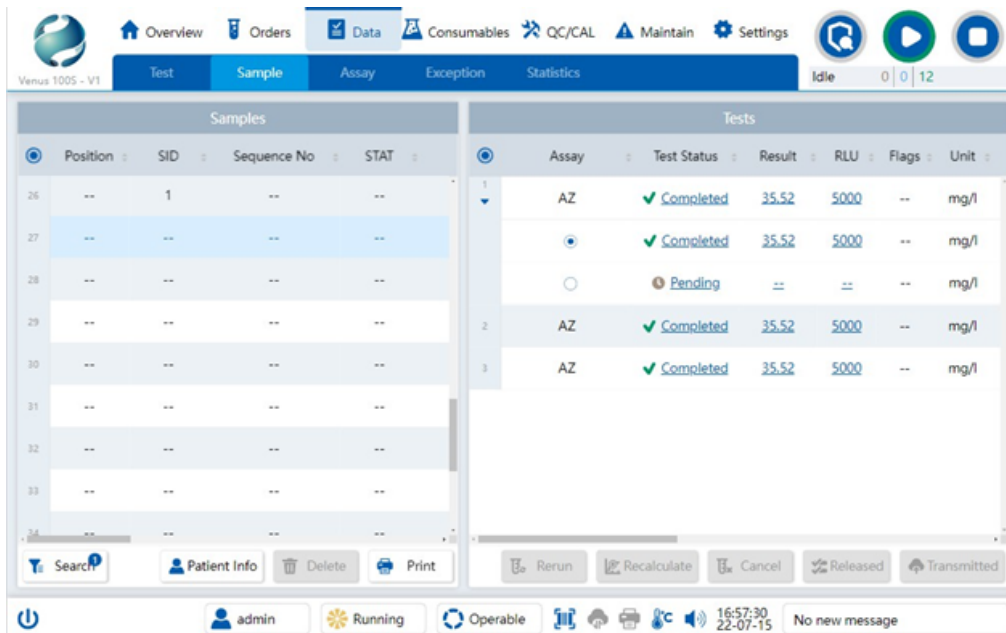

Figure: [Sample] screen under the [Data] main menu

### 11.3 Recalculate results

For scenes where recalculating test results based on the latest calibration parameters is required, the software provides the recalculation function. If test results cannot be calculated during the test process due to incomplete or failed calibration of the assay, the recalculation function can be used to recalculate the test results later. Recalculation is only available for the configured assays and only for tests with a test status of [Completed]. The recalculation operation will be recorded in the log.

- 1- On the main menu, tap [Data].
- 2- On the submenu, tap [Test], [Sample] or [Assay].
- 3- From the test list, select one or more tests to be recalculated.
- 4- Under the test list, tap the [Recalculate] button, and the selected test will be automatically recalculated based on the latest calibration parameters.

### 11.4 Cancel orders

Users can delete a test by canceling it if the test process has not started yet. One or more tests can be deleted at the same time. The operation of canceling tests will be recorded in the [Edits] log. Canceling tests will not clear the sample information. If you want to delete the sample and all related assay information, please refer to “Deletion of sample” for details.

- 1- On the main menu, tap [Data].
- 2- On the submenu, tap [Test], [Sample] or [Assay].
- 3- From the test list, select one or more tests to be deleted.
- 4- Under the test list, tap the [Cancel] button.
- 5- When a confirmation message is displayed, tap the [OK] button, and the selected test will be canceled.

## 11.5 Release results

The user can release a test result only when the status of the test is [Completed].

- 1- On the main menu, tap [Data].
- 2- On the submenu, tap [Test], [Sample] or [Assay].
- 3- From the test list, select one or more test results to be released.
- 4- Under the test list:
  - Tap the [Release] button, and the [Released] status of the test result will change from "--" to "✓".
  - Tap the [Unrelease] button to cancel the release, and the [Released] status of the test result in the list will change from "✓" to "--".

## 11.6 Transmit results

The analyzer supports both automatic and manual transmission of test results to the LIS server. The message content sent to the LIS server includes patient information and test results. When transmitting, test results are required, otherwise nothing will be sent. For more information on using the LIS server, please refer to "LIS settings".

### 11.6.1 Automatic transmission

Automatic transmission refers to the process of the analyzer automatically sending all the test results of a specimen to LIS after the tests are completed. Based on the [Transmission Mode] setting in [LIS] settings on the [System] screen under the [Settings] main menu, there are two types of automatic transmission: [Automatic] and [Released]. In [Automatic] mode, the test results will be automatically transmitted to LIS once the test status changes to [Completed]. In [Released] mode, the results will be automatically transmitted to the LIS server when the [Released] status of the test changes to "✓".

### 11.6.2 Manual transmission

Manual transmission refers to the process of the user viewing and transmitting the test results by tapping the [Transmit] button. Only tests with the [Completed] test status can be transmitted.

- 1- On the main menu, tap [Data].
- 2- On the submenu, tap [Test], [Sample] or [Assay].
- 3- In the test list, select one or more tests to be transmitted.
- 4- Under the test list, tap the [Transmit] button, and the [Transmitted] status of the test will change from "--" to "✓" on a successful transmission.

## 11.7 Print results

The analyzer can print results in a specimen report or raw data format.

### 11.7.1 Print the specimen report

- 1- On the main menu, tap [Data].
- 2- On the submenu, tap [Sample].
- 3- Under the [Samples] list, tap the [Search] button.
- 4- In the flyout, enter and select filtering conditions.
- 5- In the flyout, tap the [OK] button.



- 6- From the [Samples] list, select the specimens whose specimen report need to be printed.
- 7- Under the [Samples] list, tap the [Print] button.
- 8- In the [Print Laboratory Report] window, tap [Print] to start printing.

Print Laboratory Report

Laboratory Report

Name : --                      Patient ID: --                      Sequence No: --                      SID : --

Gender : --                      Ward : --                      Collection Dept.: --                      Attending Doctor: --

Age : --                      Bed : --                      Comment: --

---

Abbreviation	Full Name	Conc.	Reference Range	Unit
AZ	Dark Count Rate	0	0 ~ 10000	mg/l
AZ	Dark Count Rate	0	0 ~ 10000	mg/l
AZ	Dark Count Rate	0	0 ~ 10000	mg/l

---

Collection Date: --                      Observation Operator: --                      Observation Date: --                      Release Operator: --

NOTE: This report is liable for this sample only.                      Report Date: 2022-07-15 16:52:52

Figure: [Print Laboratory Report] window

### 11.7.2 Print the raw data

- 1- On the main menu, tap [Data].
- 2- On the submenu, tap [Test].
- 3- Under the test list, tap the [Search] button.
- 4- In the flyout, enter and select filtering conditions.
- 5- In the flyout, tap the [OK] button.
- 6- From the test list, select the tests to be printed.
- 7- Under the test list, tap the [Print] button.
- 8- In the [Print Raw Data] window, tap [Print] to start printing.

**Print Raw Data**



**Raw Data**

Keylights Biotechnology  
(Chongqing) Co., Ltd

Address : 60 Xingguang Avenue, Floor 7, Liangjiang  
District, Chongqing, China  
Mailbox : keylights@keylights.cn  
Phone : 023-60362990

---

Model : Venus 1005    Software Version : V1

Sample Type	Sequence No	SID	Assay	Result	RLU	Unit	Reference Range	Ordered	Completed
Control	--	--	BD	4.92	5000	g/dl	0 ~ 10000	22-07-15 16:04:30	22-07-15 16:49:37
Control	--	--	BD	4.92	5000	g/dl	0 ~ 10000	22-07-15 16:04:30	22-07-15 16:49:07
Control	--	--	BD	4.92	5000	g/dl	0 ~ 10000	22-07-15 16:04:28	22-07-15 16:48:37
Control	--	--	BD	4.92	5000	g/dl	0 ~ 10000	22-07-15 16:04:28	22-07-15 16:47:57
Control	--	--	AZ	458.21	5000	mg/l	0 ~ 10000	22-07-15 13:33:55	22-07-15 13:42:52
Control	--	--	AZ	458.21	5000	mg/l	0 ~ 10000	22-07-15 13:33:55	22-07-15 13:42:22
Control	--	--	AZ	458.21	5000	mg/l	0 ~ 10000	22-07-15 13:33:54	22-07-15 13:41:42
Control	--	--	AZ	458.21	5000	mg/l	0 ~ 10000	22-07-15 13:33:54	22-07-15 13:41:12
Control	--	--	BD	4.92	5000	g/dl	0 ~ 10000	22-07-15 12:27:50	22-07-15 13:49:26
Control	--	--	BD	4.92	5000	g/dl	0 ~ 10000	22-07-15 12:27:50	22-07-15 13:48:46
Control	--	--	BD	4.92	5000	g/dl	0 ~ 10000	22-07-15 12:27:50	22-07-15 13:50:26

---

Print By : admin Print Date : 2022-07-15 17:06:39

Figure: [Print Raw Data] window

## 11.8 Export raw data

The analyzer supports exporting raw data to a mobile device in excel file format.

### 11.8.1 Export raw data

- 1- On the main menu, tap [Data].
- 2- On the submenu, tap [Test].
- 3- Under the test list, tap the [Search] button.
- 4- In the flyout, enter and select filtering conditions.
- 5- In the flyout, tap the [OK] button.
- 6- From the test list, select the tests to be exported.
- 7- Under the test list, tap the [Export] button.
- 8- In the [Export Tests] window, select the path of the file to be exported and fill in the file name.
- 9- In the [Export Tests] window, tap the [OK] button, and the file will be saved at the selected file path.

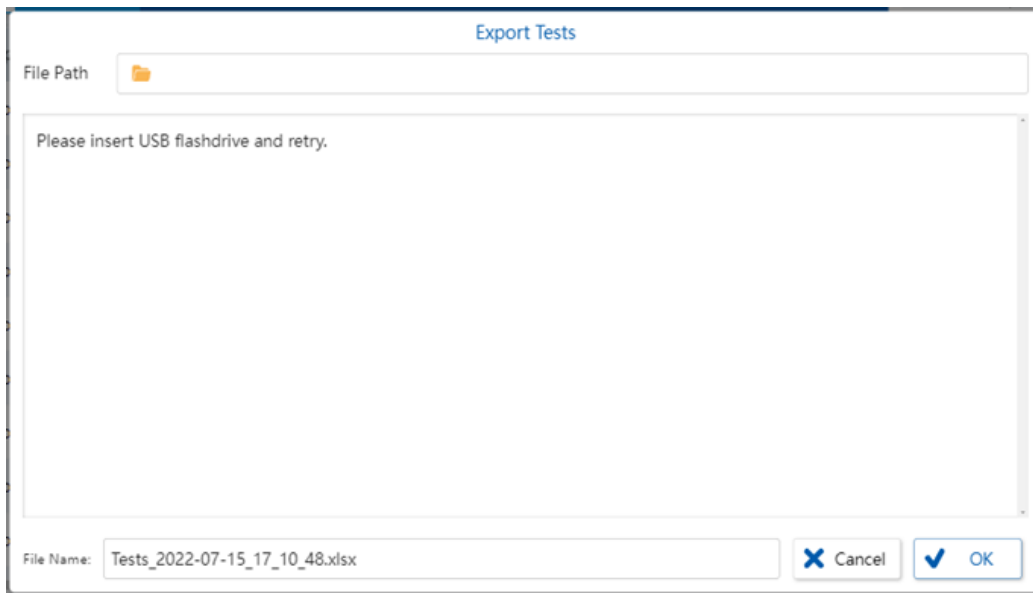

Figure: [Export Tests] window

### 11.9 Result Flags

Result flags are used to provide additional information about a result of a test or the process of a test and to indicate that the result may need to be reviewed. When multiple exceptions exist during the process and for the final evaluation, one or more result flags are displayed. The following table provides descriptions of the flag results of samples.

Flag	Sample Type	Stage	Description	Probable Cause	Corrective Action
↓	Specimen	Result	Result below the normal reference range.	The result value is below the configured normal reference range in assay settings.	No corrective action is required.
↑	Specimen	Result	Result above the normal reference range.	The result value is above the configured normal reference range in assay settings.	No corrective action is required.
↓↓	Specimen	Result	Result below the critical reference range.	The result value is below the configured critical reference range in assay settings.	No corrective action is required.
↑↑	Specimen	Result	Result above the critical reference range.	The result value is above the configured critical reference range in assay settings.	No corrective action is required.
SUBB	All	Process	Bubbles present in substrate.	Bubbles were detected while dispensing substrate.	Rerun the test as needed.
CLOT	All	Process	Pipettor clotted.	Clots were detected in the pipettor during the test procedure.	Perform the maintenance procedure for the pipettor probe and rerun the test as needed.
SAML	All	Process	Sample volume low.	Aspirated volume was reported to be zero by the pipettor during sample aspiration.	Check the sample volume and rerun the test.
RGTL	All	Process	Reagent low.	Aspirated volume was reported to be zero by the	Replace the reagent and rerun the test as needed.

				pipettor during reagent aspiration.	
--	--	--	--	-------------------------------------	--

Flag	Sample Type	Stage	Description	Probable Cause	Corrective Action
WTRL	All	Process	Cleaning solution low.	Aspirated volume was reported to be zero during cleaning solution dispensing.	Replenish the cleaning solution and rerun the test as needed.
WBL	All	Process	Wash buffer low.	Aspirated volume was reported to be zero during wash buffer dispensing.	Replenish the wash buffer and rerun the test as needed.
DTGL	All	Process	Enhanced cleaning solution low.	Enhanced cleaning solution was low or empty before the current test.	Replenish the enhanced cleaning solution and rerun the test as needed.
RGTE	All	Result	Reagent expired.	The reagent used for the test exceeded the open- bottle stability time or the expiration date.	Replace the reagent and rerun the test as needed.
RME	Control/ Calibration	Result	Reference material expired.	The reference material used or the test exceeded the open-bottle stability time or the expiration date.	Replace the reference material and rerun the test.
SUBE	All	Result	Substrate expired.	The substrate used for the test exceeded the open-bottle stability time or the expiration date.	Replace the substrate and rerun the test as needed.
CLM	Calibration	Result	Calibrator levels missing.	Results are not completed for all calibrator levels.	Redo assay calibration.
BGF	Calibration	Result	Background read failure.	The RLU read is outside the specification of the lowest calibrator.	Redo assay calibration.
DUPF	All	Result	CV% failure.	The percent coefficient of variation is larger than the allowed maximum.	Rerun test.
MONF	Calibration	Result	Monotonic behavior failure.	Results are not monotonic with reference to the concentration levels.	Redo assay calibration.
COVF	Calibration	Result	Convergence failure.	Convergence check failed while generating curve fit.	Redo assay calibration.
DEVF	Calibration	Result	Deviation failure.	The final RLU read is outside the allowed range of the current calibrator.	Redo assay calibration.

Flag	Sample Type	Stage	Description	Probable Cause	Corrective Action
RATF	Calibration	Result	Ratio failure.	The ratio of RLU reads of two different-level calibrators is larger than the allowed maximum.	Redo assay calibration.
EXT	Specimen/ Control	Process	Extended calibration.	The result is calculated with an extended calibration curve.	No corrective action is required or use a new calibration curve to recalculate.
RGTT	All	Process	Reagent temperature abnormal.	Reagent temperature was outside the normal range while being used.	Check the abnormal temperature and rerun the test as needed.

WSBT	All	Process	Wash temperature abnormal.	Wash temperature was outside the normal range while washing microparticle complex.	Check the abnormal temperature and rerun the test as needed.
INCT	All	Process	Incubation temperature abnormal.	Incubation temperature was abnormal during the test procedure.	Check the abnormal temperature and rerun the test as needed.
RLU!	All	Result	RLU error.	The RLU read is outside the range of the measurement specification.	Rerun the test.
SRR!	All	Process	System error.	System error occurred during the test procedure.	No corrective action is required or rerun the test as needed.
EDT	All	Result	Edited result.	The result has been manually edited.	No corrective action is required.
1-2s	Control	Result	Control result outside mean $\pm$ 2SD	The control result is outside the range of mean $\pm$ 2SD but within the range of mean $\pm$ 3SD.	No corrective action is required.
1-3s	Control	Result	Control result outside mean $\pm$ 3SD	The control result is outside the range of mean $\pm$ 3SD.	Check reagent stability and control stability.

Flag	Sample Type	Stage	Description	Probable Cause	Corrective Action
SUBO	All	Process	Substrate reaction overtime.	The substrate reaction time was longer than the preset.	Rerun the test as needed.
INCO	All	Process	Incubation overtime.	The incubation time was longer than the preset.	Rerun the test as needed.
WDO	All	Process	Wash overtime.	The wash time was longer than the preset.	Rerun the test as needed.

## Chapter 12 - Care and maintenance

The user must perform the care and maintenance procedures described in this chapter to ensure the appropriate operation of the analyzer and reliable results of the tests. Do not use detergents or disinfectants that can chemically react with component parts or materials of the analyzer. Please consult the manufacturer or local distributor if in doubt about the compatibility of detergents or disinfectants with component parts or materials of the analyzer. If any hazardous substance spills on the surface or leaks into the interior of the analyzer, take appropriate measures for disinfection.

### 12.1 Routine maintenance

- 1- On a daily basis, perform the [Flush analyzer water lines] and [Flush substrate water lines], or [Daily maintenance] procedure provided by the software after use.
- 2- On a daily basis, empty the RV waste container and perform proper disinfection procedures. All waste should be treated as a source of biological infection.
- 3- On a daily basis, rinse the external liquid waste container with sodium hypochlorite aqueous solution.

### CAUTION

- All manual maintenance of this chapter shall be carried out under the condition that the analyzer is powered off.
  - Do not use organic solvents like alcohol to clean the exterior cover of the analyzer.
- 4- On a daily basis, use cotton swabs dipped in 75% medical alcohol to clean the sample carousel and RV waste container after use. Turn on the laboratory UV sterilization lamp for sterilization after operators leave the laboratory.
  - 5- On a weekly basis, clean the exterior cover of the analyzer with a damp cloth.
  - 6- On a weekly basis, use cotton swabs dipped in 75% medical alcohol to clean and disinfect the pipettor to prevent cross-contamination for assays.

## 12.2 Preventive maintenance and inspection instructions

- 1- Inspect the sample racks for any obvious cuts or abrasions before use. Replace the sample racks if they are not qualified.
- 2- Inspect the bottom of the analyzer for water stains or drips during operation. If any leakage is found, replace the corresponding parts.
- 3- Inspect the water pump and air pump for any abnormal noise during operation.
- 4- Inspect the sample carousel weekly for large stains, dust, or particulate matter with a relatively large volume at each sample position. If any, clean the sample carousel in time to ensure the smoothness of the sample rack replacement.
- 5- Inspect the internal and external tubing of the analyzer weekly, and replace the tubing in time if any loose connection or leakage is found.
- 6- Inspect the ventilating fan weekly for appropriate functionality and ventilation at the back panel of the analyzer.
- 7- Inspect the external power cord weekly for any damage to ensure electrical safety.
- 8- Except for daily use, the operator must be fully trained and strictly follow the instructions when performing routine maintenance. Untrained personnel are prohibited from touching internal moving parts. Except for opening the RV waste and substrate compartment door, RV hopper cover, and sample/reagent compartment lid, all other covers require tools to open. The operator shall not open the covers that require tools.

## 12.3 Hardware Status

### 12.3.1 Temperature

To ensure the stability and validity of the test results, the sub-modules should be kept within the appropriate temperature range during the operation of the analyzer. If the temperature of any sub-module falls outside the normal range, the user should shut down the analyzer computer, turn off the power switch of the analyzer, and later power on the analyzer and restart the analyzer computer. If the problem persists, please contact the field service engineer for diagnosis and handling.

- 1- On the main menu, tap [Maintain].
- 2- On the submenu, tap [Status].
- 3- From the tabs, select the [Temperature].
- 4- The temperature information table will display the [Normal Range], and [Current Temperature] of each [Module].

## 12.4 Maintenance Operation

To ensure the appropriate function and lifespan of the components, regular maintenance should be performed, including inspection, cleaning, and replacement of analyzer components.

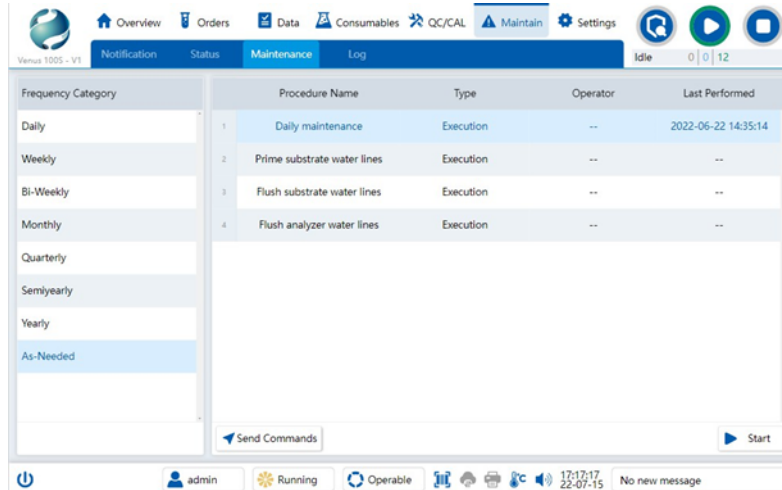

Figure: [Maintenance] screen

### 12.4.1 View maintenance procedures

Maintenance procedures are groups of maintenance operations that need to be performed at a certain frequency based on the characteristics of each component of the instrument. The frequency categories are divided into [Daily], [Weekly], [Semiyearly], [Yearly], etc. The detailed maintenance procedures for different frequency categories can be viewed following the steps below:

- 1- On the main menu, tap [Maintain].
- 2- On the submenu, tap [Maintenance].
- 3- From the [Frequency Category] list, select the applicable frequency.
- 4- On the right side of the [Frequency Category] list, all procedures will be displayed with the [Type], [Operator], and [Last Performed] of each [Procedure Name].

### 12.4.2 Maintenance commands

Maintenance commands are the maintenance procedures that are executed by the analyzer. There are two types of maintenance commands: integrated maintenance commands and unit maintenance commands.

#### Integrated maintenance commands

Integrated maintenance commands are a collection of control commands sent by the analyzer, such as [Daily maintenance], [Flush analyzer water lines], etc. All integrated maintenance commands are grouped in the [As-Needed] frequency category at the convenience of users.

#### Unit maintenance commands

A unit maintenance command is a single control command sent by the analyzer. The analyzer can send unit maintenance commands in any state. Only trained and authorized personnel is allowed to use the [Send Commands] function to move parts to an accessible location or perform maintenance-related actions.

### 12.4.3 Maintenance types and means

The types of maintenance procedures include [Execution], [Inspection], [Cleaning], [Replacement] and [Calibration].

### Automatic maintenance procedures

The [Execution] type procedure can be done by the analyzer automatically. Upon the completion of the procedure, the [Last Performed] will be updated automatically.

- 1- On the main menu, tap [Maintain].
- 2- On the submenu, tap [Maintenance].
- 3- From the [Frequency Category] list, select the applicable maintenance frequency.
- 4- From the maintenance procedures listed, select a maintenance procedure whose [Type] is [Execution].
- 5- At the bottom procedures list, tap the [Start] button.
- 6- Upon the completion of the automatic maintenance procedure, the [Last Performed] of the procedure will be updated.

**NOTE:** The maintenance operation can only be performed when the analyzer is in the [Idle] state.

### Manual maintenance procedures

The maintenance procedures of [Inspection], [Cleaning], [Replacement], and [Calibration] types need to be completed manually. The [Last Performed] needs to be updated by the user as follows:

- 1- On the main menu, tap [Maintain].
- 2- On the submenu, tap [Maintenance].
- 3- From the [Frequency Category] list, select the applicable maintenance frequency.
- 4- Perform the maintenance procedures manually as instructed.
- 5- From the maintenance procedures listed, select a maintenance procedure whose [Type] is [Inspection], [Cleaning], [Replacement], or [Calibration].
- 6- At the bottom procedures list:
  - Tap the [OK] button to update the [Last Performed] as the current system time.
  - Tap the [Cancel] button to revert the [Last Performed] to a previous record.

**NOTE:** Manual maintenance procedures should be performed with the analyzer power switched to off state.

## 12.5 Logs

The analyzer records notification messages, information editing, user operations, and maintenance procedures. Users can query, export, and print the logs if needed. The logs displayed is of the current day by default. For historical logs, please refer to the "Search" function in the "Log operations" section of this chapter.

### 12.5.1 Log type

According to the source of the logs, logs are classified into the following types: [Notifications], [Edits], [Operations], and [Maintenance].

#### Notification logs

Notification logs record all the notification messages generated during the operation of the analyzer. In the notification logs, details like [Code], [Type], [Category], [Name] [Detail], [Generated], [Recovered] and [Operator] of each notification message will be displayed.



## Edit logs

The edit logs record all addition, deletion, and modification operations of data information, such as modifying quality control rules, adding assay panels, etc. In the edit logs, details like [Time], [Category], [Detail], and [Operator] of each data edition will be displayed.

## Operation logs

The operation logs record all user control operations of the analyzer, such as start/pause, reagent replacement, etc. In the operation logs, details like [Time], [Category], [Detail], and [Operator] of each user operation will be displayed.

## Maintenance logs

The maintenance logs record all maintenance procedure. In the maintenance logs, details like [Time], [Category], [Detail] and [Operator] of each maintenance procedure will be displayed.

### 12.5.2 Log operations

#### Search

The logs support the search function, which allows the users to search logs by different query conditions.

- 1- On the main menu, tap [Maintain].
- 2- On the submenu, tap [Log].
- 3- From the tabs on the [Log] screen, select the applicable log type.
- 4- Under the log detail information list, tap the [Search] button.
- 5- In the flyout:
  - Select or enter one or more filter conditions as needed.
  - Tap the [OK] button.
- 6- The contents of the log detail information list will be refreshed and display the logs that meet the search conditions.

#### Export

The logs support the export function, which allows the user to export selected logs to a portable storage device in excel format. Before the following steps are performed, please insert a portable storage device.

- 1- On the main menu, tap [Maintain].
- 2- On the submenu, tap [Log].
- 3- From the tabs on the [Log] screen, select the applicable log type.
- 4- Under the log detail information list, tap the [Search] button.
- 5- In the flyout:
  - Select or enter one or more filter conditions as needed.
  - Tap the [OK] button.
- 6- Under the log detail information list, tap the [Export] button to display the [Export Log] window.
- 7- In the [Export Log] window:
  - Select the file path.

- Enter the file name.
  - Tap the [OK] button.
- 8- The log file will be exported in excel format with the designated file name and file path.

**Print**

The logs support the print function, which allows the users to print logs if needed.

- 1- On the main menu, tap [Maintain].
- 2- On the submenu, tap [Log].
- 3- From the tabs on the [Log] screen, select the applicable log type.
- 4- Under the log detail information list, tap the [Search] button.
- 5- In the flyout:
  - Select or enter one or more filter conditions as needed.
  - Tap the [OK] button.
- 6- Under the log detail information list, tap the [Print] button to display the [Print Log] window.
- 7- In the [Print Log] window, tap the [OK] button, and the log will be printed based on the print configurations.

**12.6 Maintenance procedures by frequency**

**12.6.1 Daily**

Procedure	Type	Operator
Daily maintenance	Execution	User
Inspect the connection of the liquid waste tubing and the connection to the external container for liquid waste.	Inspection	User
Inspect the status of the supplies.	Inspection	User

**12.6.2 Weekly**

Procedure	Type	Operator
Clean the pipettor probe exterior.	Cleaning	User
Clean the external containers.	Cleaning	User
Clean the keyboard and the touchscreen.	Cleaning	User
Inspect the pipettor probe.	Inspection	Engineer
Clean the RV waste container.	Cleaning	Engineer

**12.6.3 Monthly**

Procedure	Type	Operator
Clean the exterior of wash dispense nozzle and waste aspiration nozzle.	Cleaning	Engineer
Clean the substrate nozzle exterior.	Cleaning	Engineer
Clean the pipettor wash cup.	Cleaning	Engineer
Flush the substrate water lines.	Cleaning	Engineer
Clean the RV compartment.	Cleaning	Engineer
Clean the substrate compartment.	Cleaning	Engineer
Clean the moving parts inside the analyzer.	Cleaning	Engineer
Flush the analyzer water lines.	Cleaning	Engineer
Inspect the reagent carousel and the sample carousel.	Inspection	Engineer
Verify the analyzer configuration parameters.	Inspection	Engineer

Inspect the dispense pumps and the substrate pumps.	Inspection	Engineer
Sample carousel plate gear maintenance.	Inspection	Engineer

#### 12.6.4 Quarterly

Procedure	Type	Operator
Inspect for clots in tubing.	Inspection	Engineer
Calibrate temperatures.	Calibration	Engineer
Clean the wash mixing module.	Cleaning	Engineer
Clean the RV disposal channel.	Cleaning	Engineer
Clean the RV gripper.	Cleaning	Engineer
Clean the dust on the analyzer.	Cleaning	Engineer
Clean the crystals formed by spillages on the wash carousel.	Cleaning	Engineer

#### 12.6.5 Semiyearly

Procedure	Type	Operator
Add lubricant oil on guide rails.	Inspection	Engineer
Calibrate the precision for the sample and reagent dispense volume.	Calibration	Engineer
Calibrate the precision for the wash buffer dispense volume.	Calibration	Engineer
Calibrate the precision for the substrate dispense volume.	Calibration	Engineer
Calibrate the photomultiplier tube.	Calibration	Engineer
Replace the peristaltic pump tubing for magnetic separation.	Replacement	Engineer

#### 12.6.6 Yearly

Procedure	Type	Operator
Replace and clean the wash aspiration nozzle.	Replacement	Engineer
Clean the dust filter for the air inlet in the reagent compartment.	Cleaning	Engineer
Clean the detection compartment.	Cleaning	Engineer
Inspect sample racks.	Inspection	Engineer
Inspect moving cables.	Inspection	Engineer
Inspect the barcode reader.	Inspection	Engineer
Inspect water pumps.	Inspection	Engineer
Inspect the resistors for refrigeration.	Inspection	Engineer
Inspect the solenoid valves.	Inspection	Engineer
Inspect the sensors.	Inspection	Engineer
Inspect the statistics for parts life.	Inspection	Engineer

## Chapter 13 - Common issues and solutions

### 13.1 Forms of notification

When a notification message is generated, the analyzer will inform the user in various ways, such as the color change of software user interface elements, sound from the speaker, pop-up window in the software user interface, etc.

#### 13.1.1 Color change

In the presence of notification messages, the color of menus, data, and icons will change to notify the users. The color and description for all types of notifications are listed in the following table.

Type	Color	Description
Info	Blue	An information notification that the user needs to be aware of is present. No specific action is required.
Alert	Yellow	An alert notification condition is present, such as an abnormal status of the analyzer or test results out of the reference range. Users need to pay attention and take corrective action as needed.
Critical	Red	A critical notification condition that may affect the test result is present. Users need to take corrective actions immediately.

#### 13.1.2 Speaker sound

When a notification message is generated, the speaker will play the sound according to the configurations of the speaker.

#### 13.1.3 Pop-up window

When there is an issue that requires immediate user action or otherwise the analyzer may not be able to continue to operate, a pop-up window will display. The user should follow the instruction in the pop-up window to proceed.

#### 13.1.4 Notification center

By tapping the [Notification Center] on the lower-right corner of the user interface on any screen, users can view all unread notification messages, mark notification messages as read, and navigate to the [Notification] screen under the [Maintain] main menu to deal with the notification messages.

#### 13.1.5 Notification messages list

In the notification messages list, details like [Type], [Code], [Category], [Name] [Details], [Generated], and [Read] of each notification message will be displayed. By default, the list displays all current messages generated after the analyzer is turned on. To review historical notification messages, the user needs to navigate to the [Log] screen under the [Maintain] main menu and search with conditions under the [Notifications] tab.

#### View current notification messages

- 1- On the main menu, tap [Maintain].
- 2- On the submenu, tap [Notification].
- 3- In the notification messages list, all current notification messages will be listed. Tap the [Search] button to search for specific notification messages by entering search conditions.

#### View historical notification messages

The historical notification of the current day will be displayed in the notifications log by default.

- 1- On the main menu, tap [Maintain].
- 2- On the submenu, tap [Log].
- 3- From the tabs on the [Log] screen, select [Notifications].
- 4- Under the log detail information list, tap the [Search] button to search for specific notification messages by entering search conditions.

### **13.1.6 User interface border with breathing effect**

When there is an immediate situation that requires user action, such as command failures, the user interface will show a red border with breathing effect. Upon the confirmation of the situation, the effect will disappear.

## **13.2 Handling notifications**

During the operation of the analyzer, the analyzer will generate notification messages if any user-concerned issue happens. The notification messages may involve various aspects such as the status of reagents and supplies, test results, hardware status, etc. The analyzer provides different handling options for different notification messages. The user can view the unread notification messages from the [Notification Center] or view and handle all current notification messages in the [Notification] screen under the [Maintain] main menu.

### **13.2.1 Mark as read**

The notification messages marked as read will not be displayed in the [Notification Center].

#### **Mark as read in the notification center**

- 1- At the bottom-right corner of the software, tap the [Notification Center].
- 2- In the flyout:
  - Mark a specific message as read: At the top-right corner of the message, tap the [X] icon button.
  - Mark all messages as read: At the bottom-right corner of the flyout, tap the [mark all as read] button.

#### **Mark as read on the notification screen under the maintain menu**

- 1- On the main menu, tap [Maintain].
- 2- On the submenu, tap [Notification].
- 3- Mark a specific message as read:
- 4- From the notification messages list, select the message.
  - Under the notification messages list, tap the [mark as read] button.
- 5- Mark all messages as read:
  - Under the notification messages list, tap the [mark all as read] button.

### **13.2.2 Display help information**

Follow the steps below to open the [Help Information] window for different notification messages to view the probable cause and solution for the issue.

- 1- On the main menu, tap [Maintain].
- 2- On the submenu, tap [Notification].

- 3- From the notification messages list, tap the [Code] of a specific message to display the [Help Information] window.
- 4- In the [Help Information] window, the [Probable Cause] and [Corrective Action] will be displayed.

**Note:** Please refer to "Messages" to learn about all notifications.

### 13.2.3 Clear the notification message

The notification messages list displays all current messages. There are two approaches to clear the notification messages: automatically and manually.

#### Clear the message automatically

Upon the recognition of the corresponding issue of the notification message being eliminated, recovered, or solved, the analyzer software will set the current time as the recovery time and remove the notification message from the notification list automatically.

#### Clear the message manually

For notification messages that are statements of the facts, such as information parse failure, there is no automatic recovery approach. The users can remove them from the list manually by tapping the [Clear] button if they don't want to keep them in the list. The notification messages can be removed after being read. Command failures cannot be removed by tapping the [Clear] button.

- 1- On the main menu, tap [Maintain].
- 2- On the submenu, tap [Notification].
- 3- Clear a specific message:
  - From the notification messages list, select the message.
  - Under the notification messages list, tap the [Clear] button.
- 4- Clear all read messages:
  - Under the notification messages list, tap the [Clear All Read] button.

#### Handle command failures

For all command failures, the types are [Critical], and the categories are [Command Failure]. Command failures are generally generated of different probable cause with reference to the following detail information:

Detail	Probable Cause
Execution failure.	The controller fails to complete the execution as expected due to physical obstruction.
Response timeout.	A response is not received by the analyzer within the expected time interval.
Communication disconnected.	Connection with the controller is not properly established.

To handle a command failure, the user can take the following 3 corrective actions depending on the situation:

- 1- On the main menu, tap [Maintain].
- 2- On the submenu, tap [Notification].
- 3- From the notification messages list, select the command failure notification message.
- 4- Under the notification messages list, tap the [Handle] button.
- 5- In the flyout, the user can take the following 3 corrective actions depending on the actual situation:
  - Tap the [Auto Recover] button to try the automatic solution.

- Tap the [Mark as Handled] button to set the recovery time and remove the message from the notification list if it is a false alert due to response timeout.
- Tap the [Send Commands] button to open the [Send Command] window if extra commands need to be sent to handle the command failure.
- If the user is unsure of which action to take, please contact the field service engineer.

### 13.3 Messages

The notification message code consists of 3 parts: the source letter, the category code/the parts name, and the error code. The first letter of the code indicates the message source. A indicates that the message is an analyzer message reported by the computer, and C indicates that the message is a command failure reported by the controller. The next three numbers reflect the major categories in which the analyzer message may occur or the parts that are involved in the command failure. The last two numbers are designated as the error code for different error names. Take message code A00802 for an example: A is the source letter, 008 is the category code, and 02 is the error code. If the problem persists after corrective action is taken, contact the field service engineer for help.

#### 13.3.1 Category codes for analyzer messages reported by the computer

Category name	Category code
Information Mismatch	001
Barcode Error	002
Insufficient Reagent	003
Lot Expired	004
Stability Exceeded	005
Insufficient Supply	006
Excessive Waste	007
Communication Failure	008
Temperature Alert	009
Calibration Failure	010
QC Alert	011
Improper Operation	012
Insufficient Sample	013
Aspiration Failure	014
Pipettor Error	015
Liquid Waste Cup Error	016
Gripper Error	017

#### 13.3.2 Analyzer messages reported by the computer

Code	Type	Category	Name	Detail	Probable cause	Corrective action
A00101	Critical	Information Mismatch	Analyzer controller program version mismatch.	The analyzer controller program version is lower than the minimum required version for the software to run on full functions.	The analyzer controller program is not updated when the software version updates.	Contact the field service engineer to update the controller program version.
A00102	Info	Information Mismatch	Detected reagent volume	Reagent: XX. Record: XX. Detection: XX.	Possible intervention occurred with the	Check the reagent bottle and reagent bottle remaining information. If

			different from the record.		reagent bottle during analyzer shutdown or when the reagent bottle was not onboard. Liquid level detection malfunction.	the actual remaining value does not match the detection value, please contact our field service engineer.
A00103	Alert	Information Mismatch	Reagent remaining detection failed.	Position: XX.	The detected remaining value of the same reagent vary widely for multiple detection times.	Tap [Replace] button on the [Reagents] screen to pause the reagent system. Inspect the reagent at this position for any abnormality. After the reagent is verified OK, tap [Finish] button on the screen to recover the reagent system.
A00201	Alert	Barcode Error	Parse failure.	The barcode information cannot be parsed. Position: XXX.	The barcode is damaged. The barcode parameter configuration is not correct. The barcode reader is dirty, or the barcode reader failed.	Enter barcode manually in corresponding input fields on software screens. Clean the barcode reader or restart the barcode reader.
A00202	Alert	Barcode Error	Unable to read sample barcode.	Sample position: XXX.	The barcode on the sample tube is damaged, missing, not correctly positioned in the rack, or the barcode cannot be parsed by the built-in barcode scanner.	Ensure the barcode is supported under the current barcode configuration. Ensure that the barcode is clean and place the sample tube on the rack so that the barcode is visible to the barcode reader. Input barcode manually by keyboard or by a handheld barcode reader.
A00203	Alert	Barcode Error	Barcode duplication.	Sample code: XXX. Positions: 1. XXX. 2. XXX....	Two or more identical sample barcode is read when [Allow Duplicate Sample ID] switch in settings is off.	Check duplicate sample codes and ensure the codes are unique before placing the samples back on the carousel.
A00204	Alert	Barcode Error	Barcode duplication.	Rack code: XXX. Positions: XXX. 2. XXX....	Two or more identical rack barcode is read.	Check duplicate rack codes and ensure the codes are unique before placing the racks back on the carousel.



A00205	Alert	Barcode Error	Reagent contains unsupported assays.	Reagent position: XXX. Assay code: XXX.	The reagent contains assays that have no settings configured.	Contact the field service engineer to update the reagent information database and assay information database.
A00206	Alert	Barcode Error	Unable to read reagent barcode.	Reagent position: XXX.	The barcode on the reagent bottle is damaged, missing, not correctly positioned in the rack, or the barcode cannot be parsed by the built-in barcode reader.	Ensure the barcode is supported under the current barcode configuration. Ensure that the barcode is clean and place the reagent on the reagent carousel so that the barcode is visible to the barcode reader. Install reagent manually.
A00207	Alert	Barcode Error	An unrecorded rack code is read.	Position: XX. Rack code: XX.	An unrecorded rack code is read.	If the rack code is intended for use, please add the rack code to the [Sample Racks] in [Sample Module] on the [Factory] screen under the [Settings] main menu.
A00208	Alert	Barcode Error	A reference material barcode without concentration data is read.	Position: XX. RM type: XX. Assay code: XX. Lot: XX. Concentration level: XX.	Concentration data of this sample is not added to the system yet.	If this reference material is intended for use, please add the concentration data on the corresponding screen under the [QC/CAL] main menu.
A00301	Info	Insufficient Reagent	Remaining test count below ordered count.	Reagent: XXX. Remaining: XXX. Ordered: XXX.	The number of remaining tests in all onboard reagent bottles falls below the total ordered test number.	Install corresponding reagent.
A00302	Info	Insufficient Reagent	Remaining test count below notification value.	Reagent: XXX. Remaining: XXX.	The number of remaining tests in all onboard reagent bottles falls below the preset notification value in Settings.	Install corresponding reagent.
A00303	Alert	Insufficient Reagent	Remaining test count is 0.	Reagent: XXX.	The number of remaining tests in all onboard reagent bottles falls to 0.	Install or replace the corresponding reagent.
A00304	Alert	Insufficient Reagent	No reagent installed for assay.	Assay: XXX.	Current test orders contain an assay that is not supported by the installed reagents.	Install the corresponding reagent.

A00305	Alert	Insufficient Reagent	No reagent installed for reference material.	Assay: XXX. SID: XXX. Sample position: XXX. Sample type: XXX.	A reference material is identified but it is not matched to any of the installed reagents.	Install the corresponding reagent.
A00102	Info	Information Mismatch	Detected reagent volume different from the record.	Reagent: XXX. Record: XXX. Detection: XXX.	Possible intervention occurred with the reagent bottle during analyzer shutdown or when the reagent bottle was not onboard. Liquid level detection malfunction.	Check the reagent bottle and reagent bottle remaining information. If the actual remaining value does not match the detection value, please contact our field service engineer.
A00401	Alert	Lot Expired	Reagent expired.	Reagent: XXX. EXP date: XXX.	The reagent has reached its shelf-life expiration date.	Replace the reagent
A00402	Alert	Lot Expired	Supply expired.	Supply: XXX. EXP date: XXX.	The supply has reached its shelf-life expiration date.	Replace the supply.
A00403	Alert	Lot Expired	Calibrator expired.	Calibrator: XXX. EXP date: XXX.	The calibrator has reached its shelf-life expiration date.	Replace the calibrator.
A00404	Alert	Lot Expired	Control expired.	Control: XXX. EXP date: XXX.	The control has reached its shelf-life expiration date.	Replace the control.
A00405	Info	Lot Expired	The control is removed from related control combinations.	Control: {{name}}, control combination: {{combo1}}, {{combo2}}.	Control is expired.	No action required.
A00501	Info	Stability Exceeded	Reagent open- bottle stability exceeded.	Reagent: XXX. Days After Opened: XXX.	The reagent has reached its open-bottle stability days.	Replace the reagent.
A00502	Info	Stability Exceeded	Supply open- bottle stability exceeded.	Supply: XXX. Days after opened: XXX.	The supply has exceeded its open-bottle stability days.	Replace the supply.
A00601	Info	Insufficient Supply	Remaining test count below ordered test count.	Supply: XXX. Remaining: XXX. Ordered: XXX.	The number of remaining tests of the supply falls below the total ordered test number.	Replenish the supply.
A00602	Info	Insufficient Supply	Remaining test count below notification value.	Supply: XXX. Remaining: XXX	The number of remaining supply tests falls below the preset notification value in Settings.	Replenish the supply.

A00603	Alert	Insufficient Supply	Remaining test count is 0.	Supply: XXX.	The supply ran out or is not installed.	Replenish or install the supply.
A00604	Alert	Insufficient Supply	No RV in the RV hopper.	Sampling will be suspended.	No RV is detected in the RV hopper.	Replenish the RVs by pouring them into the RV hopper.
A00605	Alert	Insufficient Supply	Cleaning solution is insufficient.	Replenish the cleaning solution as soon as possible to avoid analyzer suspension.	The cleaning solution has reached the notification level.	Replenish the cleaning solution.
A00606	Critical	Insufficient Supply	Cleaning solution has run out.	Sampling will be suspended.	The cleaning solution is below the minimum volume.	Replenish the cleaning solution.
A00607	Alert	Insufficient Supply	Wash buffer is insufficient.	Replenish the wash buffer as soon as possible to avoid analyzer suspension.	The wash buffer has reached the notification level.	Replenish the wash buffer.
A00608	Critical	Insufficient Supply	Wash buffer has run out.	Sampling will be suspended.	The wash buffer is below the minimum volume.	Replenish the wash buffer.
A00701	Alert	Excessive Waste	Excess liquid waste in the liquid waste container.	Replace the liquid waste container as soon as possible to avoid analyzer suspension.	The liquid waste volume in the liquid waste container has reached the notification level.	Replace the liquid waste container.
A00702	Critical	Excessive Waste	The liquid waste container is full.	Sampling will be suspended.	The liquid waste volume in the liquid waste container has reached the maximum capacity.	Replace the liquid waste container.
A00703	Alert	Excessive Waste	Excess RV waste in the RV waste container.	Empty the RV waste container as soon as possible to avoid analyzer suspension.	The number of RVs in the RV waste container has reached the RV waste notification value.	Empty the RV waste container.
A00704	Critical	Excessive Waste	The RV waste container is full.	Sampling will be suspended.	The number of RVs in the RV waste container has reached the maximum capacity.	Empty the RV waste container.
A00705	Critical	Excessive Waste	RV waste chute full.	Sampling will be suspended and the dispose of RVs will be stopped.	Obstructions are detected in the RV waste chute.	Unload the RV waste container and empty it.
A00801	Alert	Communication Failure	Connection failed.	Communication Type: XXX.	The cable is physically disconnected. LIS	Check if the cable is

					server is down. The LIS settings are configured incorrectly.	disconnected. Check if the LIS server is up. Check the LIS settings.
A00802	Alert	Communication Failure	Response timeout.	SID requested: XXX.	LIS server response timeout or did not response.	Check the log to see if a response is received from the LIS server for the specified sample. If the LIS response log is not found, contact the LIS service provider for help. If the LIS response log is found, calculate the difference between the response time and the request time. Compare the time difference calculated in the previous step with the [Transmission Timeout Interval] setting of the analyzer. If the time difference is larger than the [Transmission Timeout Interval] value, increase the setting value if necessary.
A00803	Alert	Communication Failure	Information format error.	SID requested: XXX.	The encoding format of the LIS server and the analyzer is different. LIS response does not conform to the analyzer's LIS protocol.	Ensure that the analyzer use the same encoding format as the LIS server. Verify that the response message sent by the LIS server conforms to the analyzer's LIS protocol.
A00804	Alert	Communication Failure	No test information.	SID requested: XXX.	LIS response message does not contain test information. LIS response does not conform to the analyzer's LIS protocol.	Make sure the test information is included in the LIS server response message. Verify that the response message sent by the LIS server conforms to the analyzer's LIS protocol.
A00805	Info	Communication Failure	Unsupported assay code.	SID requested: XXX. Assay code: XXX.	LIS response message contains an assay code that is not configured on the analyzer.	Configure this assay code in LIS settings if this code is designated to an assay supported by this analyzer. Turn on the [Ignore Unconfigured Assay Code] switch in the LIS settings if the assay code is a redundant code sent by the LIS server and the user

						prefers not to see this notification message.
A00806	Alert	Communication Failure	Mismatch of SID.	SID requested: XXX. SID received: XXX.	The SID in the LIS response message does not match the specimen SID requested by the analyzer.	Check the log to see if the SID in this response message is matched to any SID of previous LIS requests. If no matching request is found, contact the LIS service provider. If there is a request message of the same SID, calculate the difference between the response time and the request time of this SID. Compare the time difference calculated in the previous step with the [Transmission Timeout Interval] setting of the analyzer. If the time difference is larger than the [Transmission Timeout Interval] value, increase the setting value if necessary. Contact the LIS service provider.
A00807	Alert	Communication Failure	Unsupported sample dilution factor.	SID requested: XXX. Sample dilution factor: XXX.	The dilution factor is invalid for the sample.	Edit the host order to include a valid manual dilution factor.
A00808	Alert	Communication Failure	Unsupported test dilution factor.	SID requested: XXX. Assay: XXX. Test dilution factor: XXX.	The dilution factor is invalid for the test.	Edit the host order to include a valid manual dilution factor.
A00809	Info	Communication Failure	Transmission failure.	SID: XXX. Assay: XXX.	The cable is physically disconnected. LIS connection failed. LIS server did not confirm the success of an upload transmission.	Check if the cable is properly connected. Check if the LIS server is disconnected. Manually transmit the test result after the LIS connection is restored.
A00810	Critical	Communication Failure	Barcode reader connection failed.	The analyzer will not be able to read sample code or reagent code. Please manually input the sample code in screens under the [Orders]	The cable might be loose or the barcode reader is not responding.	Contact the field service engineer to inspect the connection and functionality of the barcode reader.

				main menu or input the reagent information by manually load it on the [Reagents] screen under the [Consumables] main menu.		
A00901	Alert	Temperature Alert	Reagent compartment temperature out of range.	Normal temperature range: XXX. Current temperature: XXX.	The analyzer is still in the process of temperature control. The reagent compartment is not closed. Reduced efficiency or malfunction of the reagent carousel cooling system. Malfunction of the temperature sensor in the reagent compartment.	Wait for the analyzer temperature to stabilize, and if it does not reach the normal temperature range for a long time, follow these check steps: Check whether the reagent carousel compartment is closed properly. Check whether the cooling system of the reagent compartment is properly functioning. Check whether the temperature sensor in the reagent compartment is functioning properly. Check if there is an abnormal test result near the time of this message, and rerun the test if necessary.
A00902	Alert	Temperature Alert	Reagent compartment lid temperature out of range.	Normal temperature range: XXX. Current temperature: XXX.	The analyzer is still in the process of temperature control. The reagent compartment is not closed. Reduced efficiency or malfunction of the reagent carousel cooling system. Malfunction of the temperature sensor on the reagent compartment lid.	Wait for the analyzer temperature to stabilize, and if it does not reach the normal temperature range for a long time, follow these check steps: Check whether the reagent carousel compartment is properly closed. Check whether the cooling system of the reagent compartment is properly enabled. Check whether the temperature sensor in the reagent compartment is functioning properly. Check if there is an abnormal test result near the time of this message, and rerun the test if necessary.
A00903	Alert	Temperature Alert	Barcode reader	Normal temperature	The analyzer is still in the process of	Wait for the analyzer temperature to stabilize,

			window temperature out of range.	range: XXX. Current temperature: XXX.	temperature control. The reagent compartment is not closed. Reduced efficiency or malfunction of the reagent carousel cooling system. Reduced efficiency or malfunction of the defogging function of the reagent barcode reader window. Malfunction of the temperature sensor of the barcode reader window.	and if it does not reach the normal temperature range for a long time, following these check steps: Check whether the defogging function of the barcode reader window is properly enabled. Check whether the temperature sensor of the barcode reader window is functioning properly.
A00904	Alert	Temperature Alert	Wash buffer temperature out of range.	Normal temperature range: XXX. Current temperature: XXX.	The analyzer is still in the process of temperature control. Reduced efficiency or malfunction of the wash buffer heating module. Malfunction of the temperature sensor of the wash buffer heating module.	Wait for the analyzer temperature to stabilize, and if it does not reach the normal temperature range for a long time, following these check steps: Check whether the wash buffer heating function is properly enabled. Check whether the temperature sensor of the wash buffer heating module is functioning properly.
A00905	Alert	Temperature Alert	Incubation temperature out of range.	Normal temperature range: XXX. Current temperature: XXX.	The analyzer is still in the process of temperature control. Reduced efficiency or malfunction of the incubation heating module. Malfunction of the temperature sensor of the incubation heating module.	Wait for the analyzer temperature to stabilize, and if it does not reach the normal temperature range for a long time, following these check steps: Check whether the incubation heating function is properly enabled. Check whether the incubation temperature sensor is functioning properly.
A01001	Alert	Calibration Failure	Incomplete calibration data.	Results are not completed for calibrator levels: Cx, Cy..... Assay: XXX.	Calibration test not ordered or performed for the specified calibrator levels within a certain time frame. No calibration test result was generated for the specified calibrator	Rerun the calibration test.

					levels within a certain time frame.	
A01002	Alert	Calibration Failure	CV% failure.	The percent coefficient of variation for is larger than the allowed maximum. CV % of Cx: XXX. Allowed maximum: XXX. Assay: XXX. Calibrator: XXX. Reagent: XXX.	RV contamination. Expired calibrators. Expired reagents. Expired substrates. Malfunction of analyzer hardware.	Rerun the calibration test. If the problem persists, try the following steps: Replace the calibrators with a new one. Replace the reagents with a new one. Replace the substrates with a new one.
A01003	Alert	Calibration Failure	Background read failure.	The RLU read is outside the specification of the lowest calibrator. Assay: XXX. Calibrator: XXX. Reagent: XXX.	RV contamination. Expired calibrators. Expired reagents. Expired substrates. Malfunction of analyzer hardware.	Rerun the calibration test. If the problem persists, try the following steps: Replace the calibrators with a new one. Replace the reagents with a new one. Replace the substrates with a new one.
A01004	Alert	Calibration Failure	Monotonic behavior failure.	Results for interval (Cx, Cy) are not monotonic with reference to the concentration levels. Assay: XXX. Calibrator: XXX. Reagent: XXX.	RV contamination. Expired calibrators. Expired reagents. Expired substrates. Malfunction of analyzer hardware.	Rerun the calibration test. If the problem persists, try the following steps: Replace the calibrators with a new one. Replace the reagents with a new one. Replace the substrates with a new one.
A01005	Alert	Calibration Failure	Deviation failure.	The final RLU read of Cx is outside the allowed range of the current calibrator. Assay: XXX. Calibrator: XXX. Reagent: XXX.	RV contamination. Expired calibrators. Expired reagents. Expired substrates. Malfunction of analyzer hardware.	Rerun the calibration test. If the problem persists, try the following steps: Replace the calibrators with a new one. Replace the reagents with a new one. Replace the substrates with a new one.
A01006	Alert	Calibration Failure	Ratio failure.	The ratio of RLU reads of Cx to Cy is larger than the allowed maximum. Assay: XXX. Calibrator: XXX. Reagent: XXX.	RV contamination. Expired calibrators. Expired reagents. Expired substrates. Malfunction of analyzer hardware.	Rerun the calibration test. If the problem persists, try the following steps: Replace the calibrators with a new one. Replace the reagents with a new one. Replace the substrates with a new one.
A01101	Alert	QC Alert	QC results do not meet the control rules.	Control rule: XXX. Assay: XXX. Control: X	RV contamination. Expired controls. Expired reagents.	Rerun the QC test. If the problem persists, try the following steps:



				XX. Reagent: XXX.	Expired substrates. Malfunction of analyzer hardware.	Replace the controls with a new one. Replace the reagents with a new one. Replace the substrates with a new one.
A01201	Critical	Improper Operation	Sample compartment opened unexpectedly.	The sample compartment is opened while the sample carousel is running.	The sample compartment lid is not placed at the correct position while the sample carousel is running.	Check the sample compartment lid and ensure that it is properly placed at the correct location.
A01202	Critical	Improper Operation	Reagent compartment opened unexpectedly.	The reagent compartment is opened while the reagent carousel is running.	The reagent compartment lid is not placed at the correct position while the reagent carousel is running.	Check the reagent compartment lid and ensure that it is properly placed at the correct location.
A01301	Alert	Insufficient Sample	Sample aspiration insufficient.	SID: XXX. Position: XXX. Assay: XXX.	Sample volume below the required minimum liquid level.	Check the actual volume of the sample and make sure it is sufficient for the test. Rerun the test.
A01401	Alert	Aspiration Failure	Sample aspiration failed.	SID: XXX. Position: XXX. Assay: XXX.	Sample volume below the required minimum liquid level. Malfunction of the pipettor.	Check the actual volume of the sample and make sure it is sufficient for the test. Rerun the test.
A01402	Critical	Aspiration Failure	Continuous sample aspiration failure.	Sampling will be suspended.	Sample volume below the required minimum liquid level. Malfunction of the pipettor.	Check the actual volume of the sample and make sure it is sufficient for the test. Rerun the test.
A01403	Alert	Aspiration Failure	Reagent aspiration failed.	SID: XXX. Position: XXX. Assay: XXX. Reagent: XXX.	Reagent volume below the required minimum liquid level. Malfunction of the pipettor.	Check the actual volume of the reagent and make sure it is sufficient for the test. Rerun the test.
A01404	Alert	Aspiration Failure	Dilution aspiration failed.	SID: XXX. Position: XXX. Assay: XXX.	Diluent volume below the required minimum liquid level. Malfunction of the pipettor.	Check the actual volume of the diluent and make sure it is sufficient for the test. Rerun the test.
A01405	Critical	Aspiration Failure	Enhanced cleaning solution aspiration failed.	Sampling will be suspended.	Enhanced cleaning solution volume below the required minimum liquid level. Malfunction of the pipettor.	Check the actual volume of the enhanced cleaning solution and make sure it is sufficient for the test. Rerun the test.

A01501	Critical	Pipettor Error	Clots present.	Sampling will be suspended.	Clots are detected. Malfunction of the pipettor clots sensor.	Contact the field service engineer.
A01502	Critical	Pipettor Error	Liquid detection error.	Sampling will be suspended.	Malfunction of the pipettor liquid level sensor.	Contact the field service engineer.
A01601	Critical	Liquid Waste Cup Error	Liquid waste cup full.	Sampling will be suspended and pipettor probe cleaning will be stopped.	Liquid waste cup is abnormally full before the cycle ends.	Contact the field service engineer to inspect the liquid waste cup for blockage.
A01602	Critical	Liquid Waste Cup Error	Liquid waste drain failure.	Sampling will be suspended and pipettor probe cleaning will be stopped.	Liquid waste cup remains full after flushing.	Contact the field service engineer to inspect the liquid waste pump.
A01701	Critical	Gripper Error	Offset of the gripper trigger pad is deviated.	Gripper trigger pad is deviated towards the open direction and it should be adjusted to the right. Current position: XX. Gripper trigger pad is deviated towards the origin and it should be adjusted to the left. Current position: XX.	Gripper trigger pad is deviated.	Contact the field service engineer to adjust the trigger pad.

### 13.3.3 Parts codes for command failure messages reported by the controller

Parts Name	Parts Code
Sample Carousel	001
Reagent Carousel	002
Pipettor	003
Dispense Mixing	004
Dispense Carousel	005
RV Alignment Slide	006
Gripper	007
Wash Carousel	008
Wash Mixing	009
Incubation and Detection Carousel	010
Photometer	011
Barcode Reader	012
Control Board	013
RV Waste Container	014
External Container	015

### 13.3.4 Command failures reported by the controller

Code	Name	Detail
C00101	Reset the sample carousel.	Execution failure / Response timeout / Communication disconnected
C00102	Rotate the sample carousel to scan sample barcode.	Execution failure / Response timeout / Communication disconnected
C00103	Rotate the sample carousel to aspirate sample.	Execution failure / Response timeout / Communication disconnected
C00104	Rotate the sample carousel to expose reader window.	Execution failure / Response timeout / Communication disconnected
C00105	Rotate the sample carousel to scan diluent barcode.	Execution failure / Response timeout / Communication disconnected
C00106	Rotate the sample carousel to aspirate diluent.	Execution failure / Response timeout / Communication disconnected
C00107	Rotate the sample carousel to scan enhanced cleaning solution barcode.	Execution failure / Response timeout / Communication disconnected
C00108	Rotate the sample carousel to aspirate the enhanced cleaning solution.	Execution failure / Response timeout / Communication disconnected
C00109	Turn on sample carousel interlock.	Execution failure / Response timeout / Communication disconnected
C00110	Monitor the specimen compartment lid status.	Execution failure / Response timeout / Communication disconnected
C00111	Monitor the specimen carousel control buttons.	Execution failure / Response timeout / Communication disconnected
C00112	Rotate the sample carousel to replace sample rack.	Execution failure / Response timeout / Communication disconnected
C00113	Set the enabling status of the specimen carousel control button.	Execution failure / Response timeout / Communication disconnected
C00114	Set the light color of the specimen carousel control button.	Execution failure / Response timeout / Communication disconnected
C00115	Set the light color of the exterior light strip.	Execution failure / Response timeout / Communication disconnected
C00201	Reset the reagent carousel.	Execution failure / Response timeout / Communication disconnected
C00202	Rotate the sample carousel to aspirate reagent.	Execution failure / Response timeout / Communication disconnected
C00203	Rotate the sample carousel to replace reagent.	Execution failure / Response timeout / Communication disconnected
C00204	Rotate the sample carousel to scan reagent barcode.	Execution failure / Response timeout / Communication disconnected
C00205	Turn on mixing magnetic microparticles.	Execution failure / Response timeout / Communication disconnected
C00206	Turn off mixing magnetic microparticles.	Execution failure / Response timeout / Communication disconnected
C00207	Turn on the barcode reader window temperature stabilizing.	Execution failure / Response timeout / Communication disconnected
C00208	Turn off the barcode reader window temperature stabilizing.	Execution failure / Response timeout / Communication disconnected
C00209	Read the temperature of the reagent carousel.	Execution failure / Response timeout / Communication disconnected
C00210	Turn on reagent carousel interlock.	Execution failure / Response timeout / Communication disconnected

C00211	Monitor the reagent compartment lid status.	Execution failure / Response timeout / Communication disconnected
C00212	Monitor the reagent carousel control buttons.	Execution failure / Response timeout / Communication disconnected
C00213	Set the enabling status of the reagent carousel control button.	Execution failure / Response timeout / Communication disconnected
C00214	Set the light color of the reagent carousel control button.	Execution failure / Response timeout / Communication disconnected
C00215	Turn on the reagent carousel refrigerator.	Execution failure / Response timeout / Communication disconnected
C00216	Turn off the reagent carousel refrigerator.	Execution failure / Response timeout / Communication disconnected
C00217	Read reagent refrigeration PWM percentage.	Execution failure / Response timeout / Communication disconnected
C00218	Configure mixing parameters for computer off-line status.	Execution failure / Response timeout / Communication disconnected
C00301	Reset the pipettor.	Execution failure / Response timeout / Communication disconnected
C00302	Initialize the pipettor	Execution failure / Response timeout / Communication disconnected
C00303	Detect the remaining volume of reagent.	Execution failure / Response timeout / Communication disconnected
C00304	Clean pipettor after liquid level detection.	Execution failure / Response timeout / Communication disconnected
C00305	Clean the pipettor.	Execution failure / Response timeout / Communication disconnected
C00306	Clean the exterior of the pipettor.	Execution failure / Response timeout / Communication disconnected
C00307	Rotate the pipettor to aspirate the enhanced cleaning solution.	Execution failure / Response timeout / Communication disconnected
C00308	Aspirate the enhanced cleaning solution.	Execution failure / Response timeout / Communication disconnected
C00309	Rotate the pipettor to aspirate the diluent.	Execution failure / Response timeout / Communication disconnected
C00310	Aspirate the diluent.	Execution failure / Response timeout / Communication disconnected
C00311	Dispense the supply (diluent or enhanced cleaning solution).	Execution failure / Response timeout / Communication disconnected
C00312	Rotate the pipettor to aspirate sample.	Execution failure / Response timeout / Communication disconnected
C00313	Aspirate the sample.	Execution failure / Response timeout / Communication disconnected
C00314	Dispense the sample.	Execution failure / Response timeout / Communication disconnected
C00315	Rotate the pipettor to aspirate the reagent.	Execution failure / Response timeout / Communication disconnected
C00316	Aspirate the reagent.	Execution failure / Response timeout / Communication disconnected
C00317	Dispense the reagent.	Execution failure / Response timeout / Communication disconnected
C00318	Rotate the pipettor to dispense position.	Execution failure / Response timeout / Communication disconnected

C00319	Aspirate the diluted sample.	Execution failure / Response timeout / Communication disconnected
C00320	Reset pipettor due to motion counter.	Execution failure / Response timeout / Communication disconnected
C00321	Read pipettor pressure sensor.	Execution failure / Response timeout / Communication disconnected
C00322	Clean pipettor with enhanced cleaning solution.	Execution failure / Response timeout / Communication disconnected
C00323	Move pipettor probe to the bottom of RV.	Execution failure / Response timeout / Communication disconnected
C00324	Move pipettor probe to magnet attraction position.	Execution failure / Response timeout / Communication disconnected
C00401	Reset the dispense mixing module.	Execution failure / Response timeout / Communication disconnected
C00402	Start the dispense mixing module.	Execution failure / Response timeout / Communication disconnected
C00403	Restart the dispense mixing module.	Execution failure / Response timeout / Communication disconnected
C00501	Reset the dispense carousel.	Execution failure / Response timeout / Communication disconnected
C00502	Rotate the dispense carousel.	Execution failure / Response timeout / Communication disconnected
C00503	Read RV presence on dispense carousel.	Execution failure / Response timeout / Communication disconnected
C00601	Turn on automatic RV arrangement.	Execution failure / Response timeout / Communication disconnected
C00602	Turn off automatic RV arrangement.	Execution failure / Response timeout / Communication disconnected
C00603	Query RV arrangement status.	Execution failure / Response timeout / Communication disconnected
C00604	Monitor RV alignment failure.	Execution failure / Response timeout / Communication disconnected
C00701	Reset the gripper.	Execution failure / Response timeout / Communication disconnected
C00702	Move gripper to incubation position.	Execution failure / Response timeout / Communication disconnected
C00703	Move gripper to detection position.	Execution failure / Response timeout / Communication disconnected
C00704	Move gripper to dispensing position.	Execution failure / Response timeout / Communication disconnected
C00705	Move gripper to mixing position.	Execution failure / Response timeout / Communication disconnected
C00706	Move gripper to wash position.	Execution failure / Response timeout / Communication disconnected
C00707	Move gripper to disposal position.	Execution failure / Response timeout / Communication disconnected
C00708	Grip the RV.	Execution failure / Response timeout / Communication disconnected
C00709	Grip the RV.	No RV grasped
C00710	Release the RV.	Execution failure / Response timeout / Communication disconnected
C00711	Release the RV.	RV not released

C00712	Transfer the RV from position to position.	Execution failure / Response timeout / Communication disconnected
C00713	Transfer the RV from position to position.	No RV grasped
C00714	Transfer the RV from position to position.	RV not released
C00715	Grip the RV.	RV grip failed
C00716	Grip the RV.	Collision happened in gripping
C00717	Release the RV.	RV dropped during transfer
C00718	Release the RV.	Collision happened in releasing
C00719	Transfer the RV from position to position.	RV grip failed
C00720	Transfer the RV from position to position.	Collision happened in gripping
C00721	Transfer the RV from position to position.	RV dropped during transfer
C00722	Transfer the RV from position to position.	Collision happened in releasing
C00801	Reset the wash carousel on Z-axis.	Execution failure / Response timeout / Communication disconnected
C00802	Reset the wash carousel rotation.	Execution failure / Response timeout / Communication disconnected
C00803	Rotate the wash carousel.	Execution failure / Response timeout / Communication disconnected
C00804	Prime the substrate.	Execution failure / Response timeout / Communication disconnected
C00805	Dispense the wash buffer on wash carousel.	Execution failure / Response timeout / Communication disconnected
C00806	Dispense the substrate on wash carousel.	Execution failure / Response timeout / Communication disconnected
C00807	Ascend RV on wash carousel to upper position.	Execution failure / Response timeout / Communication disconnected
C00808	Descend RV on wash carousel to lower position.	Execution failure / Response timeout / Communication disconnected
C00809	Turn on wash carousel heating.	Execution failure / Response timeout / Communication disconnected
C00810	Turn off wash carousel heating	Execution failure / Response timeout / Communication disconnected
C00811	Read the wash carousel temperature	Execution failure / Response timeout / Communication disconnected
C00812	Soak the waste aspiration nozzle.	Execution failure / Response timeout / Communication disconnected
C00813	Aspirate waste during wash.	Execution failure / Response timeout / Communication disconnected
C00814	Add substrate during wash.	Execution failure / Response timeout / Communication disconnected
C00815	Add wash buffer during wash.	Execution failure / Response timeout / Communication disconnected
C00816	Clean the swab.	Execution failure / Response timeout / Communication disconnected
C00901	Reset wash mixing module.	Execution failure / Response timeout / Communication disconnected
C00902	Start wash mixing module.	Execution failure / Response timeout / Communication disconnected
C01001	Reset the incubation carousel.	Execution failure / Response timeout / Communication disconnected
C01002	Rotate the incubation carousel.	Execution failure / Response timeout / Communication disconnected

C01003	Rotate the detection carousel.	Execution failure / Response timeout / Communication disconnected
C01004	Rotate the detection carousel to the photometer position.	Execution failure / Response timeout / Communication disconnected
C01005	Turn on incubation carousel temperature stabilizing.	Execution failure / Response timeout / Communication disconnected
C01006	Turn off incubation carousel temperature stabilizing.	Execution failure / Response timeout / Communication disconnected
C01007	Read the incubation carousel temperature	Execution failure / Response timeout / Communication disconnected
C01008	Reset the incubation carousel motion counter.	Execution failure / Response timeout / Communication disconnected
C01009	Prime trigger.	Execution failure / Response timeout / Communication disconnected
C01101	Read RLU.	Execution failure / Response timeout / Communication disconnected
C01102	Photometer power control.	Execution failure / Response timeout / Communication disconnected
C01201	Scan barcode.	Execution failure / Response timeout / Communication disconnected
C01202	Configure the barcode reader.	Execution failure / Response timeout / Communication disconnected
C01301	Query the version of board 1.	Execution failure / Response timeout / Communication disconnected
C01302	Query the version of board 2.	Execution failure / Response timeout / Communication disconnected
C01303	Query the version of board 3.	Execution failure / Response timeout / Communication disconnected
C01304	Query the version of board 4.	Execution failure / Response timeout / Communication disconnected
C01305	Unseize motors of board 1.	Execution failure / Response timeout / Communication disconnected
C01306	Unseize motors of board 2.	Execution failure / Response timeout / Communication disconnected
C01307	Unseize motors of board 3.	Execution failure / Response timeout / Communication disconnected
C01308	Open valves of board 1.	Execution failure / Response timeout / Communication disconnected
C01309	Close valves of board 1.	Execution failure / Response timeout / Communication disconnected
C01310	Open valves of board 2.	Execution failure / Response timeout / Communication disconnected
C01311	Close valves of board 2.	Execution failure / Response timeout / Communication disconnected
C01312	Open valves of board 3.	Execution failure / Response timeout / Communication disconnected
C01313	Close valves of board 3.	Execution failure / Response timeout / Communication disconnected
C01401	Read RV waste container status.	Execution failure / Response timeout / Communication disconnected
C01402	Read RV waste chute status.	Execution failure / Response timeout / Communication disconnected

C01501	Read external container sensor status.	Execution failure / Response timeout / Communication disconnected
--------	--	--

## Chapter 14 - Precautions and requirements

### 14.1 Precautions during installation

- 1- The analyzer should be kept at a distance of at least 50cm from the wall or other instruments where the space buffer is enough to access the disconnection device and perform the maintenance procedure. Do not install the analyzer at a location where it is difficult to reach the disconnection device (power switch, power input socket, plug, etc.).
- 2- Ventilation requirement: Do not block the analyzer cooling vent to avoid damage to the analyzer caused by heat. The vents should be kept unobstructed.
- 3- Do not change the location of the analyzer after installation. For information about the relocation of the analyzer, please contact the manufacturer or the local distributor.
- 4- Do not install this analyzer in close proximity to sources of strong electromagnetic radiation, as this can interfere with the appropriate operation.
- 5- To avoid electromagnetic interference, the external container should be installed directly below or to the left of the analyzer. These two locations have been verified by EMC tests to receive no electromagnetic interference.



### 14.2 Precautions with operation

- 1- Before operating the system, inspect tubing and connectors for leakage. Leakage can lead to biological contamination, damage to the analyzer, and inaccurate aspiration/ dispense volume.
- 2- Before using reagents and samples, inspect for bubbles and insoluble floating matters such as cellulose, fibrin, etc. These matters can cause blockage of the pipettors or the water lines of the wash components, which will affect the appropriate operation of the analyzer and the accuracy of the test results.
- 3- Wait until the incubator temperature reaches the preset value before starting assay tests. The accuracy of the test results may be affected if the assays start before the temperature is reached.
- 4- The operator should take protective measures such as wearing medical gloves when dealing with leaks and tubing blockage.
- 5- The sample rack position should correspond to the actual sample rack position when entering the sample information.
- 6- If the barcode reading fails for samples, the operator can take out the sample rack, adjust the sample barcode position and then try again or enter the sample information manually.
- 7- Please use calibrators for calibration before performing assay tests for specimens.
- 8- When the analyzer is paused during the testing process, only the sample aspiration process will be suspended. The tests that have finished sample aspiration will not be affected.
- 9- Tapping the [Stop] icon button will stop the analyzer from all mechanical movements. Tapping the [Start] icon button will resume the operation of the analyzer. The time in between should be as short as possible due to the possibility of causing deviated results for the assay tests in the system. Please operate with caution.
- 10- It is recommended to run the assay tests with a shorter incubation time first and then the assay tests with a longer incubation time. This can improve the efficiency of the analyzer.



- 11- The reagents used on this analyzer must be the validated reagents of the analyzer manufacturer. No other reagent is allowed.
- 12- Before operating the system, operators should read the operations manual carefully and ensure the following standards. The specimen volume is no less than 500 µl. The reference material volume is no less than 150 µl. The reagent volume in the reagent bottle is no less than 500 µl. In addition, the operating environment should also meet the Environmental specifications and requirements.
- 13- If an operation error is made, the operator should stop further operation immediately and contact the manufacturer for a solution. At the end of the lab tests, the operator should take out the reagents as soon as possible and store them according to the reagent instructions for storage.
- 14- If the user needs to add validated reagents for use, relevant parameters should be authorized or configured by the analyzer manufacturer.
- 15- The specified reaction vessels are required for tests. Using other reaction vessels will lead to failure of the analyzer's RV arrangement module and test exceptions.

### 14.3 Safety precautions

- 1- Do not open the cover of the analyzer to avoid unnecessary human and machine injuries caused by mishandling, especially where there is a  (Do not touch the internal parts) warning symbol.
- 2- Please be careful with the sharp parts of the analyzer, which are often accompanied by  warning symbols to remind operators of extra caution, such as the pipettor tip, steel poles of the wash components, etc., to avoid human injuries such as cuts and puncture wounds caused by touching them.
- 3- When the analyzer is operating, do not touch the moving parts such as the pipettor, wash components, fans, belts, etc.
- 4- All specimens, calibrators, controls, liquid wastes, and parts that may have contact with them, such as the pipettor, wash components, liquid waste tubing, etc., as well as parts labeled with the  warning signs are considered as potentially infectious matters. Protections like medical gloves are required when handling the above matters and performing the maintenance or repair procedure of the analyzer.
- 5- Immediately clean an affected area with water and seek medical attention if any exposure to biohazardous or potentially infectious materials occurs (wash buffer, liquid waste, specimen, etc.).
- 6- Please hold the plug instead of pulling the power cord when unplugging the power supply.
- 7- Operators must be trained before being allowed to perform hazardous operations.
- 8- Operators shall not open the covers with fixed screws.
- 9- The sample compartment of the analyzer contains a laser barcode reader. The operator should not look directly at the barcode reader window when the analyzer is turned on. According to IEC 60825-1:2014, the radiation generated by the barcode reader belongs to class 1 laser radiation. The operator should avoid direct laser to the eyes during the operation, maintenance, and repair of the analyzer.

### 14.4 Other precautions

- 1- The analyzer should not be powered off during operation. If there is a power failure, the tests in the system will be invalidated. It is recommended to connect the analyzer to an uninterrupted power supply.
- 2- When a common error happens during operation, the analyzer will initiate automatic protection within 5 seconds. The user does not need to turn off the instrument. The user should contact the manufacturer for remote assistance with diagnosis and recovery. Common failures include abnormal mechanical sounds during operation, etc.

- 3- In case of a critical problem, the user should disconnect the power supply immediately and contact the manufacturer for assistance. Critical problems include water leakage of the water lines, short circuits in the power supply, etc.
- 4- During the operation, the analyzer should be reliably grounded to avoid interfering with the test results or accidents due to poor electrical ground.
- 5- Ensure that the connection between the power plug and the analyzer is correct and reliable. When the connection needs to be changed, please disconnect the power switch before unplugging. In case of malfunction or unsolvable issues, stop the operation immediately. Turn off the power switch, unplug the power supply and contact the manufacturer for assistance.
- 6- This analyzer is an in vitro diagnostic product used for clinical qualitative or quantitative analysis of analytes in human serums. Please do not use this product beyond the intended use.
- 7- The results of this analyzer are for clinical reference only. For the clinical significance of a specific assay, please refer to the instructions of the supporting reagents. Please also consider clinical manifestations and opinions from medical personnel.
- 8- Incorrect parameter configuration and operation errors can lead to wrong test results. Please ask the operators to take the training provided by the representatives carefully or consult the reagent supplier.
- 9- The analyzer should not share a power outlet with other irrelevant power-using instruments. Frequent power switching of other power-using instruments sharing the same line may interfere with this analyzer, thus affecting the stability of the analyzer. Therefore, it is recommended to assign an uninterruptible power supply (UPS) exclusively for this analyzer.
- 10- Do not use flammable hazardous materials near the instrument, such as alcohol, ether, etc.
- 11- Please avoid any impact on or collision with the analyzer to avoid damage to both the internal and external parts of the analyzer.
- 12- Please do not put other foreign objects into the analyzer to avoid destructive problems.
- 13- Please do not put liquid containers or small metal objects on the analyzer. If liquid or metal objects are accidentally dropped into the analyzer, please cut off the power supply, unplug it and contact the manufacturer for assistance in time.
- 14- Please follow the hospital or local regulations to dispose the analyzer at the end of its life.
- 15- The key component of this analyzer is the photomultiplier tube, whose recommended service life is 5 years.
- 16- At the end of each day's use, please use the dust cover accompanied to prevent particle pollution.
- 17- Keep the cover of the RV hopper closed at all times when the analyzer is not in use to prevent particle pollution in the RV arrangement module.

## **Chapter 15 - Transportation and storage**

### **15.1 Transportation**

The packaged products can be transported by general transportation but violent impact or vibration should be avoided. Moisture-proof and rain-proof measures should be taken. After the analyzer is consigned to the responsible party, the responsible party shall transport it according to the labels on the packing box.

The package shall be handled gently and shall not be transported with flammable and explosive items. Since the equipment is heavy, handling tools, such as forklifts, must be used in the handling process and the process shall be completed by at least two people.

During the transportation or disposal process after the analyzer is used, the operator may be exposed to the residual biohazard sources in the analyzer. To ensure the safety of personnel, biohazard sources in the analyzer should be effectively handled and controlled, such as proper cleaning procedures performed before the shutdown, proper disposal of waste on time, timely drainage of piping systems to avoid leakage, etc.

## 15.2 Storage

The packaged products should be stored indoors at a temperature range of  $-20^{\circ}\text{C} \sim +50^{\circ}\text{C}$ , with a relative humidity of less than 95%, and an atmospheric pressure range of 650hPa  $\sim$  1060hPa. The storage environment should be well ventilated with no corrosive gas.

## Chapter 16 - After-sales services

### 16.1 Warranty period

The warranty period of the analyzer is determined by the sales contract. The installation for the first time, regular maintenance, and repair of non-human caused malfunctions (including accessories) are provided free of charge within the warranty period by the manufacturer or the authorized distributor.

#### CAUTION

The user is strictly prohibited from any disassembly or modification of the analyzer, including the software system. The prohibited misconduct will void the warranty of the analyzer.

### 16.2 Maintenance and replacement of consumable parts

Of all the parts of this analyzer, only the fuse and external silicone tubing can be replaced by the user. All other parts shall be replaced by the authorized personnel of the analyzer manufacturer or authorized distributor on-site using parts provided by the analyzer manufacturer or authorized distributor.

#### WARNING

All component replacement must be performed with the analyzer powered off.

Table: List of consumable parts

Consumable parts				
■ Maintenance & Inspection ▲ Replacement				
Part	Quarterly	Semi-Annually	Annually	Biennially
Liquid Waste Tubing		▲		
Peristaltic Pump Tubing		▲		
Filter			▲	
Substrate Piston Pump				▲
Isolation Valve				▲
Pipettor Probe	■			
Water Pump			■	

Wash Dispense Nozzle	■			
----------------------	---	--	--	--

### 16.2.1 Replacement of fuse

Turn off the analyzer, disconnect the power supply and unplug it. Locate the fuse in the middle of the black three-pin power socket mounted at the lower right position at the back of the analyzer. Pull the fuse out, and install a new one (F4A L250V).

#### WARNING

Unplug the power supply before the replacement.

### 16.2.2 Replacement of tubing

Turn off the analyzer, remove the corresponding silicone tubing identified by the labels at the back of the analyzer, and replace the corresponding silicone tubing.

#### WARNING

- When disconnecting tubing, avoid spillage of the fluid in the tubing.
- When connecting new tubing, please pay attention to the label of the tubing being connected.

### 16.3 Calibration of the analyzer

The operating facility is required to have the instrument calibrated yearly according to the calibration procedures specified in this manual and to keep the calibration records. The calibration procedure is required to be performed by trained and qualified personnel only.

#### 16.3.1 Mechanical performance

##### Requirements:

- 1- The gripper can pick up and delivers the RV normally and accurately.
- 2- All transportation components of the dispense system operate appropriately.
- 3- All transportation components of the wash system operate appropriately.
- 4- The moving parts of the analyzer should move smoothly without sudden jams or jumps.
- 5- Fasteners should be firmly and reliably connected without loosening.
- 6- The analyzer should run smoothly and without strange noises.

##### Method:

Open the top cover of the analyzer and observe the movement of each system module.

#### 16.3.2 Incubation temperature

##### Requirements:

The temperature range of the incubation carousel should be within  $37^{\circ}\text{C}\pm 0.5^{\circ}\text{C}$ , and the fluctuation should not exceed  $0.5^{\circ}\text{C}$ .

##### Method:

Inspect the incubation temperature using a temperature sensor with a precision of 0.1°C or higher, or the specific verified tooling provided by the manufacturer. Place one temperature sensor at the following two positions each: the entrance for the inner circle of the incubation carousel and the temperature monitoring position. Wait till the temperature stabilizes, and read the temperature every 30 seconds for 10 minutes. The difference between the average temperature and the preset temperature is the measurement bias. The temperature fluctuation is half of the difference between the highest and lowest measurement bias. The temperature range and fluctuation should meet the requirements.

### 16.3.3 Calibration of dispense volume and wash residual volume

#### Requirements:

The wash residual volume should not exceed 5µL. The dispense volume should be in line with the requirements of Table: Dispense volume requirements.

Table: Dispense volume requirements

Category	Dispense Category	Dispense Volume	Deviation	Coefficient of variation CV)/%
Sample	Minimum dispense volume	5µL	Less than ±1µL	≤5
	Maximum dispense volume	100µL	Less than ±5%	≤2
Reagent	Minimum dispense volume	15µL	Less than ±10%	≤3
	Maximum dispense volume	200µL	Less than ±5%	≤2

#### Method:

Put the RV on the wash station, and send the command for wash via the analyzer adjustment software. After the wash process, use the weighing method to measure the residual volume in the RV. The volume should not be more than 5µL. If the residual volume is more than 5µL, adjust the distance from the aspiration nozzle to the bottom of the RV till the wash residual volume is less than 5µL.

Put the RV on the dispense carousel, and send the commands for dispense via the analyzer adjustment software. After the dispense process, use the weighing method to measure the dispense volume. If the dispense volume does not meet the requirements of Table: Dispense volume requirements, send relevant commands to clean the pipettor probe and adjust the parameters via the analyzer adjustment software.

### 16.3.4 Photomultiplier tube performance

#### Requirements:

- 1- Dark count rate ≤200 RLU/s.
- 2- Consistency within 90%~110%.
- 3- CV% < 1%.

#### Method:

- 1- Install the reference light source in the detection room.
- 2- Start the adjustment software and choose photomultiplier tube calibration.
- 3- Record 3 metrics of the calibration test result from step 2.

### 16.3.5 Correlation coefficient

**Requirements:**

Linear correlation coefficient (r) should be  $\geq 0.99$  when  $RLU \geq 3$  RLU.

## Chapter 17 - Electromagnetic compatibility

The analyzer complies with the requirements of emission and immunity specified in IEC 61326-2-6:2020. See the table below.

Table 17-1:

Electromagnetic Emission	
Emission Test	Conformity
Mains Terminal Disturbance Voltage	Class A
Electromagnetic Radiation Disturbance	Group 1 Class A @ 10m

Table 17-2:

Electromagnetic Immunity		
Description	Value	Conformity
Electrostatic Discharge Immunity	Contact Discharge: $\pm 2$ kV, $\pm 4$ kV Air Discharge: $\pm 2$ kV, $\pm 4$ kV, $\pm 8$ kV	B
Electromagnetic Field Immunity	3V/m, 80MHz~6.0GHz, 80%AM	A
Fast Transient Burst Immunity – AC Power Port	Power Cable: $\pm 1$ kV (5/50ns, 100kHz) I/O Signal Cable: N/A	B
Surge Immunity - AC Power Port	Line-to-earth: $\pm 1$ kV Line-to-line: $\pm 0.5$ kV	B
RF Conducted – AC Power Port	Power Cable: 3V/m, 150kHz-80MHz, 80%AM I/O Signal Cable: N/A	A
Power Frequency Magnetic Field	3A/m, 50Hz	A
Short Interruptions – AC Power Port	250/300 cycles: 0%	C
Voltage Dips – AC Power Port	0.5 cycle: 0%.	B
	1 cycle: 0%.	C
	25/30 cycles: 70%.	C
<b>Performance Assessment:</b>		
In the test, the performance is normal when the results are within the limits stipulated in the specifications.		
In the test, the function or performance degrades temporarily or is lost, but can be restored automatically.		
In the test, the function or performance degrades temporarily or is lost, but the operator should interfere in it or reset the system.		

### 17.1 Electromagnetic emission and immunity

#### 17.1.1 Radio frequency radiation

The functionality of the analyzer does not make use of the RF energy. Therefore, its RF emission level is low and unlikely to interfere with nearby electronic instruments.

#### 17.1.2 Radiation immunity

- 1- Portable and mobile RF communication equipment may cause interference to the analyzer. Portable and mobile RF communication equipment should be greater than 30cm away from the analyzer. Other

instruments operating in the vicinity of the analyzer at the same time should meet the requirements of electromagnetic compatibility.

- 2- The analyzer is suitable for use in all facilities that are not domestic and not directly connected to the public residential low-voltage network. The analyzer is designed for use in a PROFESSIONAL HEALTHCARE FACILITY ENVIRONMENT. It is likely to perform incorrectly if used in a HOME HEALTHCARE ENVIRONMENT. If it is suspected that performance is affected by electromagnetic interference, correct operation may be restored by increasing the distance between the equipment and the source of the interference.
- 3- The electromagnetic field in the intended installation site should be measured to ensure that it is sufficiently low. The analyzer should be kept away from electromagnetic field sources. Magnetic shielding materials should be installed under particular conditions to ensure the appropriate operation of the analyzer.

## 17.2 Installation environment

- 1- Power outlets should have reliable protective grounding measures, and the accompanying power cords, parts, and accessories should be used.
- 2- The power grid should be of a typical commercial or hospital environment quality.
- 3- If the analyzer is required to operate during a power interruption, it is recommended to connect the analyzer to an uninterruptible power supply.
- 4- The floor of the installation site should be wood, concrete, or tile. If the floor is covered with a synthetic material, ensure that the relative humidity is at least 30%.

## 17.3 External devices

- 1- For the handheld barcode reader used with the analyzer, the length of the connecting cable and the power cable are both less than 3m, and the cables are both unshielded cables.
- 2- For the external container liquid level sensors accompanied by the analyzer, the length of the connecting cables is all less than 3m, and they are all shielded cables.
- 3- For other external devices that meet the analyzer's EMC requirements, the length of the communication cable should be shielded cable less than 3m.

## WARNING

- Using accessories and cables other than those provided by the manufacturer of this analyzer as internal components may result in an increase in RF emissions from the analyzer or a decrease in radiation immunity.
- This analyzer should not be used in close proximity to other instruments or stacked with other instruments. If it has to be used in close proximity to other instruments or stacked with other instruments, the appropriate operation of the analyzer should be verified in the unrecommended environment.
- Users have the responsibility to ensure the electromagnetic compatibility of the environment in which the analyzer operates appropriately. While operating the analyzer, the requirements should be strictly followed or otherwise cause electromagnetic interference to other instruments or reduce the electromagnetic immunity of the analyzer, or even suffer a loss of basic performance.
- It is prohibited to operate the analyzer next to strong radiation sources (e.g., unshielded RF sources) due to the possibility of interference with the appropriate operation of the analyzer.

- The analyzer is designed and tested according to the standards of Class A instruments in IEC 61326-2-6:2020. The analyzer is not intended for use in residential environments and may not provide adequate protection to radio reception in such environments.

It is recommended to evaluate the electromagnetic environment of the installation site before the operation of the analyzer, and it is the users' responsibility to ensure that the electromagnetic environment of the analyzer meets the requirements.